

Profi Carrier (3-axle)

» Type: ADP 27 eL4-CS

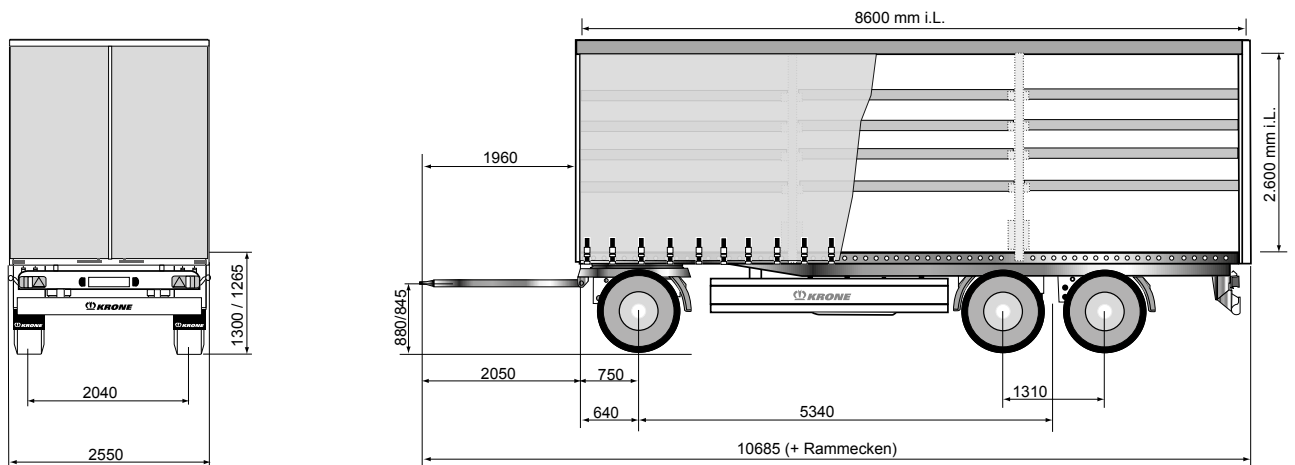

3 axle drawbar trailer in curtainsider design



Technical data	
Type:	ADP 27 eL4-CS
Axle load:	24,000 kg
Allowable gross weight:	24,000 kg
Tare weight approx.:	5,340 kg
Construction height at front:	140 mm
Axle spread:	5,340 mm
Chassis height, unloaded:	1,300 mm
Internal length:	8,600 mm
Drawbar length:	2,050 mm
Internal width:	2,480 mm
Internal height:	2,600 mm
Total length (centre draw bar eye), approx.:	10,685 mm

(Dimensions and weights for standard units)

Are you already familiar with Krone's services?

SPARE PARTS

TELEMATICS

FAIR CARE

MOBILITY

SERVICE LOCATOR

Find out more about:
www.krone-trailer.com/english/service

Technical description:	
Multi Lock side rave including load securing positions every 100 mm	Alloy cant rail, continuous, for support of sliding curtain and posts, Edscha sliding roof; diagonal roof spanning; 5 sets of alloy planks
Low maintenance steering pivot and draw bar with rubber baring and retaining spring	Front wall with solid corner posts; front wall reinforced with plywood inner skin
Low-maintenance axles with air suspension and disc brakes (430 mm); including raise and lower valve, 2 valves	Container rear doors including bolted steel frame, integrated double door looks and concealed door hinges; roof header hinged and movable; clamping device for tarpaulin with ratchet at the rear frame
Tyres: 6 x 385/65 R 22.5, brand: Krone choice	2 pairs of side posts, oppositely positioned; plank pockets for posts
Spare wheel carrier as an option	Delta shaped rubber profiles at rear; delta steel buffers at rear; load security certificate according EN 12642 Code XL
Wheel covering according to EC-regulations; Spray suppression according to EC-guidelines	1 PVC curtain with full lengths vertical reinforcements, top with rollers for sliding curtains, bottom with tensioners, curtain tensioner out of stainless steel; roof tarpaulin in white
Brake system according to EC-regulation 13; with electronic stability system spring parking brake; EBS-braking system, 4S/3M, 4 sensors on 2 axles; Diagnostics by ISO7638 plug connection (EBS supply cable)	Steel parts shot blasted, with KTL primer and high-quality surface coating (standard painting single-colour); axles incl. wheel hubs painted black; under-run protection and light panel coated white for safety reasons; wheels silver with high-quality paint finish; reflective outline marking according to ECE-R48
Lights according to UN ECE reg. no. 48; 24 volts lighting system with 2 x 7-pin socket DIN ISO 1185/3731; front and rear marker lights; two multi-function rear lights incl. rear fog light and reversing lights; contouring lights, number plate lights and side marker lights in LED	
30 mm thick, phenolic coated plywood floor, cut surfaces fully waterproofed and sealed. Strength acc. to DIN EN 283; for floor loadings up to 5,460 kg stacker-truck axle load	

