

Load Carrier (building material)

» Type: AZP 18 eL41-BS

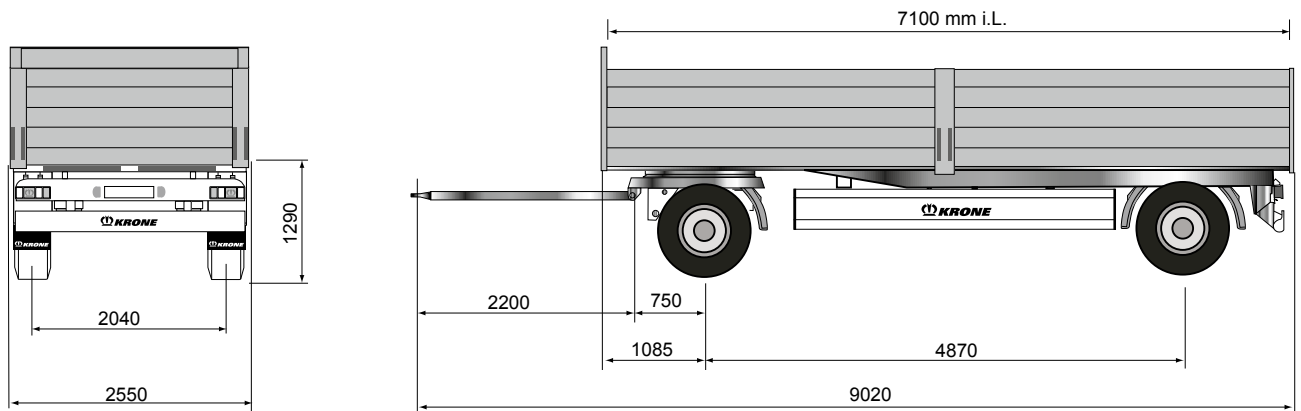

2 axle drawbar trailer for transporting building material



Technical Data	Option	Option	Standard	Option
Type:	AZP 18 eL41-BS	AZP 18 eL41-BS	AZP 18 eL41-BS	AZP 18 eL41-BS
Axle load:	18,000 kg	18,000 kg	18,000 kg	18,000 kg
Allowable gross weight:	18,000 kg	18,000 kg	18,000 kg	18,000 kg
Tare weight approx.:	3,620 kg	3,680 kg	3,710 kg	3,740 kg
Payload approx.:	14,380 kg	14,320 kg	14,290 kg	14,260 kg
Axle spread:	4,485 mm	4,885 mm	4,870 mm	5,070 mm
Chassis height, unloaded:	1,290 mm	1,290 mm	1,290 mm	1,290 mm
Front overhang:	985 mm	985 mm	1,085 mm	1,085 mm
Height front wall:	1,200 mm	1,200 mm	1,200 mm	1,200 mm
Height side walls:	1,000 mm	1,000 mm	1,000 mm	1,000 mm
Side access length:	6,500 mm	6,900 mm	7,100 mm	7,300 mm
Side access width:	2,480 mm	2,480 mm	2,480 mm	2,480 mm
Total length (centre draw bar eye), approx.:	8,520 mm	8,920 mm	9,020 mm	9,220 mm

(Dimensions and weights for standard units)

Technical description:	
Multi Lock side rave including load securing positions every 100 mm	Without roof
Low maintenance steering pivot and draw bar with rubber baring and retaining spring	Steel front wall with solid corner posts for free lateral loading; front wall reinforced with plywood inner skin;
Low-maintenance axles with air suspension and disc brakes (430 mm); including raise and lower valve, 2 valves	2 drop sides on each side, anodized; hinged/removable, tension rod; without crimp profile; with integrated folding steps; side walls prepared for the installation of a dropside lifting aid
Tyres: 4 x 385/65 R 22.5, brand: Krone choice	Alloy rear wall, anodized; hinged and removable, tension rod; rear wall without crimp profile
Spare wheel carrier as an option	1 pair of Kinnegrip middle stanchions as well as Kinnegrip corner stanchions front and rear; corner stanchions rear mounted crosswise
Wheel covering according to EC-regulations; Spray suppression according to EC-guidelines	Rear impact protection through delta ram profiles
Brake system according to EC-regulation 13; with electronic stability system spring parking brake; EBS-braking system, 4S/3M, 4 sensors on 2 axles; Diagnostics by ISO7638 plug connection (EBS supply cable)	Load securing certificate according to EN 12642 Code XL
Lights according to UN ECE reg. no. 48; 24 volts lighting system with 2 x 7-pin socket DIN ISO 1185/3731; front and rear marker lights; two multi-function rear lights incl. rear fog light and reversing lights; contouring lights, number plate lights and side marker lights in LED	Steel parts shot blasted, with KTL primer and high-quality surface coating (standard painting single-colour); axles incl. wheel hubs painted black; under-run protection and light panel coated white for safety reasons; wheels silver with high-quality paint finish; reflective outline marking according to ECE-R48
30 mm thick, phenolic coated plywood floor, cut surfaces fully waterproofed and sealed. Strength acc. to DIN EN 283; for floor loadings up to 5,460 kg stacker-truck axle load	

