

Box Liner

» Type: SDC 27 eL40'

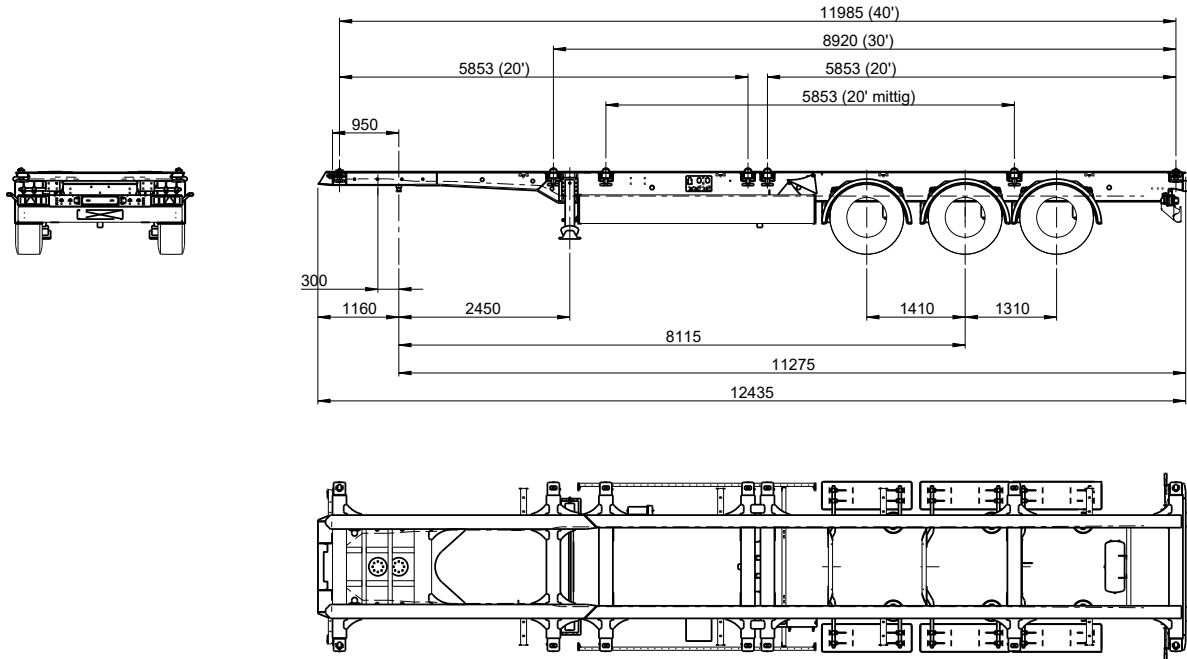

Chassis with corresponding locks for container transport: 1 x 40', 2 x 20' and 1x 20' on-centre loaded (up to 30 tons), 30' rear flush



Technische Daten

Type:	SDC 27 eL40'
King Pin load:	16,000 kg
Axle load (technically possible):	27,000 kg
Perm. total weight (technically possible):	43,000 kg
Tare weight:	approx. 4,900 kg
Payload (technically possible):	approx. 38,100 kg
Axle spread:	1,410 / 1,310 mm
5th wheel height:	1,150 mm
Neck height (incl. coupling plate):	200 mm
Distance kingpin - rear end:	11,275 mm

(Dimensions and weights for standard units)

Load distribution:

Loading options	Total weight of containers (kg)	Coupling load		Axle load		Total weight (kg)
		(kg)	(%)	(kg)	(%)	
40'	36,500	14,420	35	26,980	65	41,400
2x 20'	2x 18,250	14,420	34	26,980	66	41,400
20' on-centre	30,000	9,260	27	25,640	73	34,900
30'	28,000	4,970	18	26,880	82	22,900

Technical description

Chassis made of I beams welded to crossmembers; neck height: 200 mm (incl. coupling plate); bolted 2" kingpin, 2 positions: 650 and 950 mm, mounted on 950 mm; rear underrun protection and side guards acc. to EC regulation

Container lockings for 1 x 40', 2 x 20', 1 x 20' on-centre up to 30 tons and 30' rear flush

Fixed side protection behind the assembly

2 mechanically operated landing legs, 2 x 12 tones capacity, half round compensating feet

Low-maintenance axles with air suspension and disc brakes (430 mm); raise/lower valve incl. auto reset valve; Rims centre nave

Tyres: 6 x 385/65 R 22.5, brand: Krone choice

Wheel covering according to EC-regulations; Spray suppression according to EC-guidelines

spare wheel carrier as an option

EC braking system including vehicle stabilising system; low-maintenance automatic; spring-loaded hand brake; 2S/2M EBS system, 2 sensors on each axle with RSS, diagnostics on ISO 7638 socket (EBS)

24 volts lighting system with 2 x 7-pin socket DIN ISO 1185/3731; front and rear marker lights; with two multi-function rear lights acc. to EC incl. rear fog light and reversing lights; 2 large contouring lights with rubber arm in LED; side marker lights in LED

Steel parts shot blasted, with KTL primer and high-quality surface coating (standard painting single-colour); axles incl. wheel hubs painted black; underrun protection and light panel coated white for safety reasons; wheels silver with high-quality paint finish; accessories black or galvanized; reflective outline marking according to ECE-R48

