

# Box Liner

» Type: SDC 27 eL45'

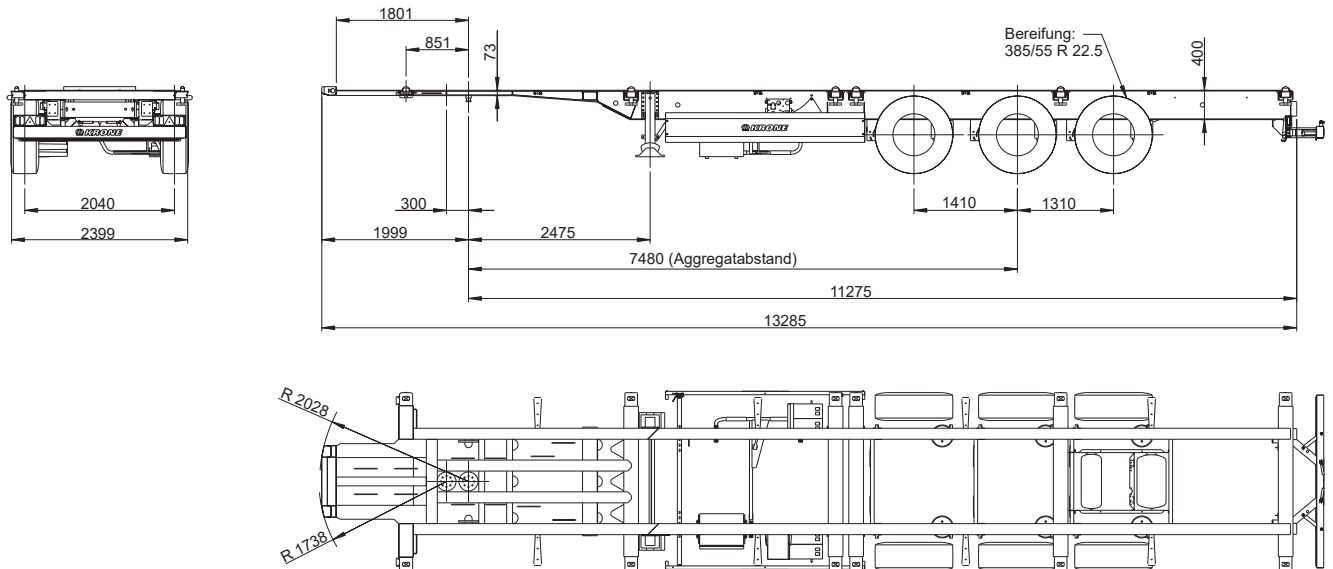

Chassis with corresponding locks for container transport: 1 x 40'; 1 x 45' with 40' locking position, as well as: 2 x 20'; 1 x 20' on-centre up to 25 tons and 1 x 30' rear-flush



**Attention: The transport of filled tank containers is prohibited!**

Technical data	
Type:	SDC 27 eL45
King Pin load:	14,000 kg
Axle load (technically possible):	27,000 kg
Perm. total weight (technically possible):	41,000 kg
Tare weight:	approx. 4,760 kg
Payload (technically possible):	approx. 36,240 kg
Axle spread:	1,410 / 1,310 mm
5th wheel height:	1,050 mm
Neck height (incl. coupling plate):	70 mm
Distance kingpin - rear end:	11,275 mm

(Dimensions and weights for standard units)

Technical description:	
Chassis made of I beams welded to crossmembers; neck height: 70 mm (incl. coupling plate); bolted 2" kingpin, 2 positions: 551 and 851 mm, mounted on 851 mm; pneumatic extendable rear; rear underrun protection and side guards acc. to EC regulation	
Container lockings for 40' and 45' containers with 40' locking position; as well as: 2 x 20'; 1 x 20' on-centre up to 25 tons and 1 x 30' rear-flush	
Available on request: rear bulb plate platform	
2 mechanically operated landing legs, 2 x 12 tones capacity, half round compensating feet	
Low-maintenance axles with air suspension and disc brakes (430 mm); raise/lower valve incl. auto reset valve; Rims centre nave	
Tyres: 6 x 385/55 R 22.5, brand: Krone choice	
Wheel covering according to EC-regulations; Spray suppression according to EC-guidelines	
spare wheel carrier as an option	
EC braking system including vehicle stabilising system; low-maintenance automatic; spring-loaded hand brake; 2S/2M EBS system, 2 sensors on each axle with RSS, diagnostics on ISO 7638 socket (EBS)	
24 volts lighting system with 2 x 7-pin socket DIN ISO 1185/3731; front and rear marker lights; with two multi-function rear lights acc. to EC incl. rear fog light and reversing lights; 2 large contouring lights with rubber arm in LED; side marker lights in LED	
Steel parts shot blasted, with KTL primer and high-quality surface coating (standard painting single-colour); axles incl. wheel hubs painted black; underrun protection and light panel coated white for safety reasons; wheels silver with high-quality paint finish; accessories black or galvanized; reflective outline marking according to ECE-R48	

Load distribution:						
Loading options	Total weight of containers (kg)	Coupling load		Axle load		Total weight (kg)
		(kg)	(%)	(kg)	(%)	
45'	33,700	11,360	30	27,000	70	38,360
40'	33,700	11,360	30	27,000	70	38,360
2x 20'	2x 16,580	11,360	30	27,000	70	38,360
20' on-centre	25,000	8,720	29	20,880	71	29,600

