

Box Liner

» Type: SDC 27 eLTU4

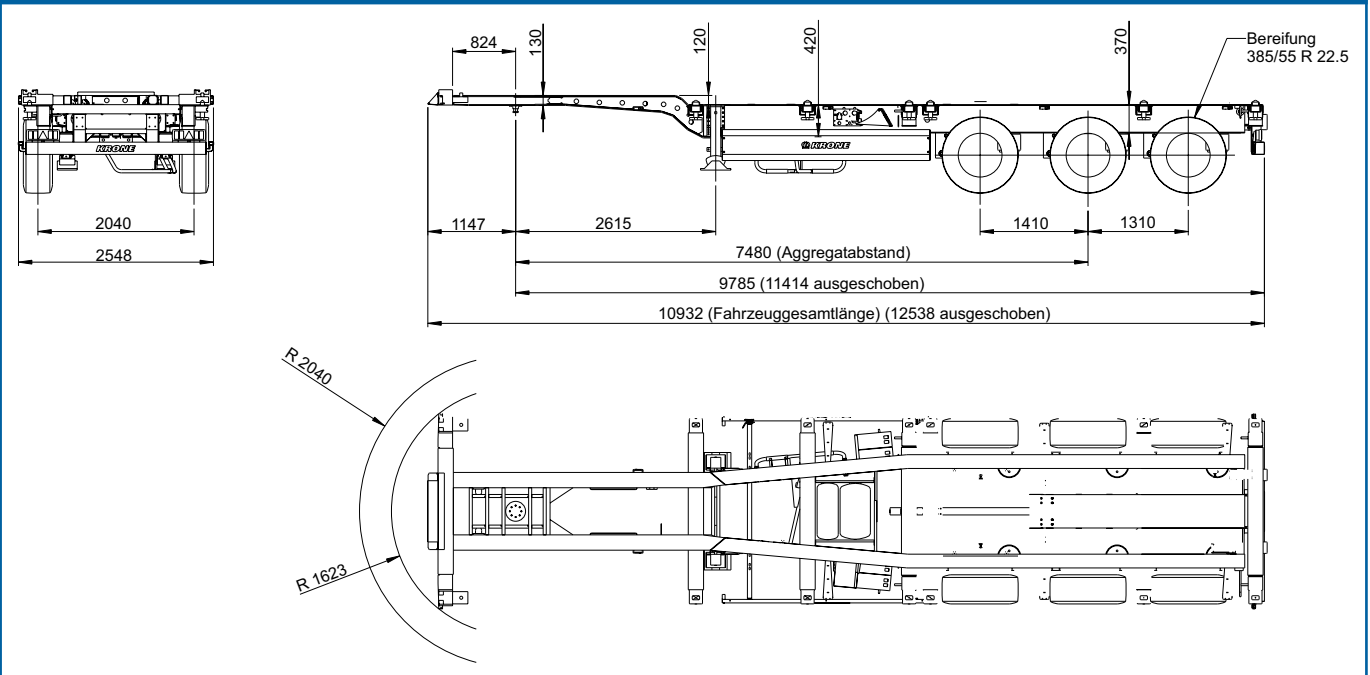

Chassis with corresponding locks for container transport: 1 x 40' (with tunnel), 2 x 20', 1 x 20' heckbündig, 1 x 20' on-centre up to 30 tons and 1 x 30' rear-flush



Attention: The transport of filled tank containers is prohibited!

Technical data	
Type:	SDC 27 eLTU4
King Pin load:	14,000 kg
Axle load (technically possible):	27,000 kg
Perm. total weight (technically possible):	41,000 kg
Tare weight:	approx. 5,030 kg
Payload (technically possible):	approx. 35,970 kg
Axle spread:	1,410 / 1,310 mm
5th wheel height:	1,100 mm
Neck height (incl. coupling plate):	130 mm
Distance kingpin - rear end:	11,414 mm

(Dimensions and weights for standard units)

Load distribution:						
Loading options	Total weight of containers (kg)	Coupling load		Axle load		Total weight (kg)
		(kg)	(%)	(kg)	(%)	
1x 20' rear flush	25,190	3,710	12	27,000	88	30,710
1x 20' on-centre	30,000	9,740	27	25,780	73	35,520
2x 20'	2x 15,945	10,410	28	27,000	72	37,410
40' HighCube/ISO	31,890	10,410	28	27,000	72	37,410
30' rear flush	24,720	3,240	11	27,000	89	30,240

Technical description
Chassis made of I beams welded to crossmembers; cranking 120 mm; neck height: 130 mm (incl. coupling plate); bolted 2" kingpin, mounted on 825 mm; pneumatic extendable rear; rear underrun protection and side guards acc. to EC regulation
Container lockings for 1 x 40' (with tunnel), 2 x 20', 1 x 20' rear flush, 1 x 20' on-centre up to 30 tons and 1 x 30' rear-flush
rear bulb plate platform
Available on request: Height adjustable container lockings and foldable supports (for transport of container without tunnel)
2 mechanically operated landing legs, 2 x 12 tones capacity, half round compensating feet
Low-maintenance axles with air suspension and disc brakes (430 mm); raise/lower valve incl. auto reset valve; Rims centre nave
Tyres: 6 x 385/55 R 22.5, brand: Krone choice
Wheel covering according to EC-regulations; Spray suppression according to EC-guidelines
spare wheel carrier as an option
EC braking system including vehicle stabilising system; low-maintenance automatic; spring-loaded hand brake; 2S/2M EBS system, 2 sensors on each axle with RSS, diagnostics on ISO 7638 socket (EBS)
24 volts lighting system with 2 x 7-pin socket DIN ISO 1185/3731; front and rear marker lights; with two multi-function rear lights acc. to EC incl. rear fog light and reversing lights; 2 large contouring lights with rubber arm in LED; side marker lights in LED
Steel parts shot blasted, with KTL primer and high-quality surface coating (standard painting single-colour); axles incl. wheel hubs painted black; underrun protection and light panel coated white for safety reasons; wheels silver with high-quality paint finish; accessories black or galvanized; reflective outline marking according to ECE-R48



Fahrzeugwerk Bernard KRONE GmbH & Co. KG
 Bernard-Krone-Straße 1, 49757 Werlte, GERMANY
 Phone: +49 (0) 5951 209-0, Fax: +49 (0) 5951 209-98-268

Subject to modifications!
 VF/Beu issue 04/2021