

3 axle refrigerated trailer in Double deck style with ATP/FRC certificate – side view and rear view

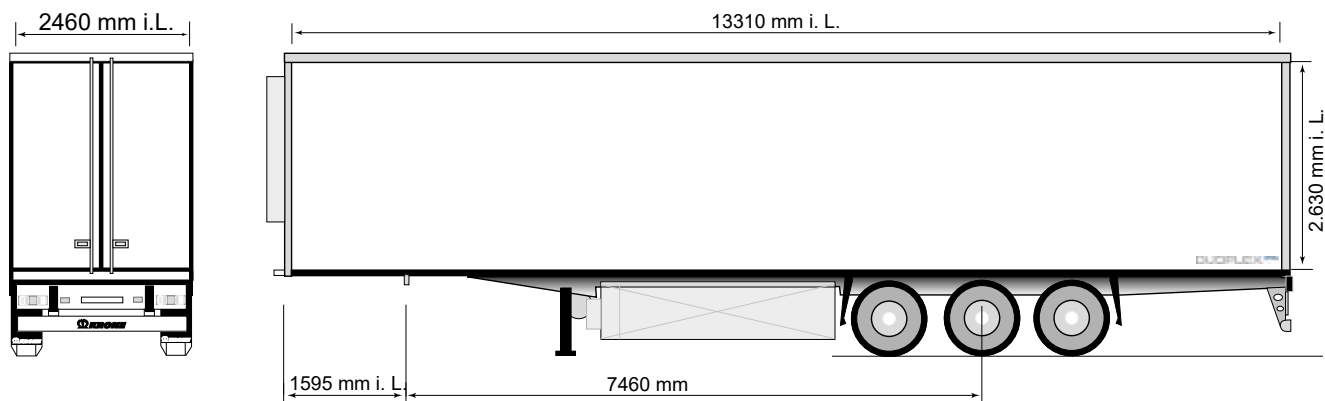

**Technical data**

Type:	SDR 27 eL4-DS
King Pin load:	12,000 kg
Axle load (technically possible):	27,000 kg
Perm. total weight (technically possible):	39,000 kg
Tare weight (without cooling unit):	approx. 7,840 kg
Coupling height unloaded:	1,150 mm
Axle spread:	1.310 / 1,310 mm
Internal length:	13,310 mm
Internal width:	2,460 mm
Internal height:	2,630 mm

Dimensions and weights for standard units)

**Are you already familiar with Krone's services?**



Find out more about:  
[www.krone-trailer.com/english/service](http://www.krone-trailer.com/english/service)

**Technical description:**

Continuous chassis construction with double T/Z-profile longitudinal beams and cross members; rear traverse with diagonal reinforcements, neck height: 10 mm	Box in thermal bridge free panel construction, panels on both sides with steel outer skin, painted outside, inside PVC coated; 100 % CFC-free foam
Mechanically operated landing legs, 2 x 12 tonnes capacity, leveling foot half round with base plate	Roof as sandwich panel; LED ceiling lamps, door contact switch for ceiling lamps
Low-maintenance axles with air suspension and disc brakes (430 mm), offset 120; raise/lower valve (1 valve) incl. auto reset	Front wall as sandwich panel; floor connection with chafe-resistant alloy kick strip; 4 vertical alloy distance profiles for optimal air flow; front wall with bolted protection wall
Tyres: 6 x 385/65 R 22.5, brand: Krone choice	Side wall as sandwich panel; floor connection with chafe-resistant kick strip; Double deck device for 33 additional Euro pallets in 2nd loading level consisting of 12 pairs of vertically recessed aluminium guide rails and 22 aluminium double deck loading beams.
Spare wheel carrier as an option	Container type double rear doors with 3 alloy hinges per door; sealing system with outside dust protection, V2A portal frame with airlock sealing edge above and below; two outer one-hand comfort closure door lockings; chafe resistant alloy kick strips inside die doors; door retainer
Wheel cover with splash guard according to EC regulations	Air duct; ATP-certificate; load securing certificate Code XL; cooling unit on request for extra charge
Brake system according to ECE R 13 (including vehicle stabilising system); spring parking brake; 2S/2M EBS system, 2 sensors on one axle, diagnostics by ISO 7638 socket (EBS)	Steel parts shot blasted, KTL-primed and with high quality surface coating; axles incl. wheel hubs in KTL black; underrun protection and light supports coated white for safety reasons; wheels silver with high-quality finish; accessories black or galvanized; laminate coating coloured in RAL 9010 white; reflective outline marking according to ECE-R48
Lights according to UN ECE reg. no. 48; 2 x 7-pin socket DIN ISO 1185/3731; contouring lights, number plate lights and side marker lights in LED; multi function rear lights incl. rear fog light and 1 reversing light	
Plastic fuel tank, approx. 240 litres (when equipped with cooling unit); closed pallet box for 36 Euro-pallets, 1 PVC tool box	
Low-noise alloy floor; strength acc. to DIN EN 283; for floor loadings up to 5.500 kg stacker-truck axle load; reinforced at rear	