

3 axle refrigerated trailer in Multitemp style with ATP/FRC certificate – side view and rear view

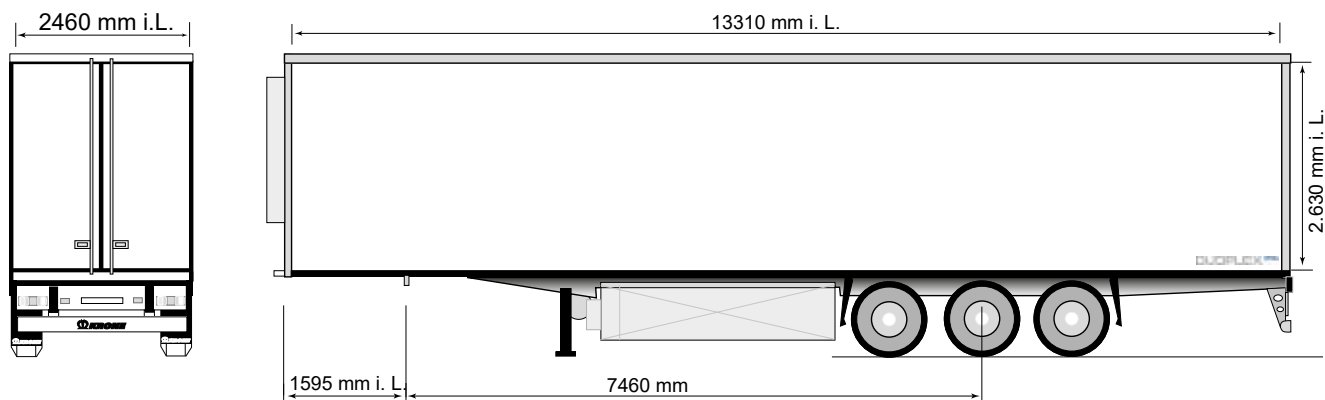

Technical data	
Type:	SDR 27 eL4-MT
King Pin load:	12,000 kg
Axle load (technically possible):	27,000 kg
Perm. total weight (technically possible):	39,000 kg
Tare weight (without cooling unit):	ca. 7,830 kg
Coupling height unloaded:	1,150 mm
Axle spread:	1,310 / 1,310 mm
Internal length:	13,310 mm
Internal width:	2,460 mm
Internal height:	2,630 mm

(Dimensions and weights for standard units)

**Are you already familiar with Krone's services?**

SPARE PARTS

TELEMATICS

FAIR CARE

MOBILITY

SERVICE LOCATOR

Find out more about:  
[www.krone-trailer.com/english/service](http://www.krone-trailer.com/english/service)

Technical description:	
Continuous chassis construction with double T longitudinal beams and cross members; rear traverse with diagonal reinforcements, neck height: 10 mm	Box in thermal bridge free panel construction, panels on both sides with steel outer skin, painted outside, inside PVC coated; 100 % CFC-free foam
Mechanically operated landing legs, 2 x 12 tonnes capacity, leveling foot half round with base plate	Roof as sandwich panel; LED-flush ceiling lamps, door contact switch for ceiling lamps; Reinforcement for additional evaporator and roof duct for refrigeration lines
Low-maintenance axles with air suspension and disc brakes (430 mm), offset 120; raise/lower valve (1 valve) incl. auto reset	Front wall as sandwich panel; floor connection with chafe-resistant kick strip; 4 vertical alloy distance profiles for optimal air flow; front wall with bolted protection wall
Tyres: 6 x 385/65 R 22.5, brand: Krone choice	Side wall as sandwich panel; floor connection with chafe-resistant kick strip
Spare wheel carrier as an option	Container type double rear doors with 3 alloy hinges per door; sealing system with outside dust protection, V2A portal frame with airlock sealing edge above and below; two outer one-hand comfort closure door lockings; chafe resistant alloy kick strips inside die doors; door retainer
Wheel cover with splash guard according to EC regulations	Air duct; ATP-certificate; load securing certificate Code XL; cooling unit on request for extra charge; Hinged and movable bulkhead with overhead locking device
Brake system according to ECE R 13 (including vehicle stabilising system); spring parking brake; 2S/2M EBS system, 2 sensors on one axle, diagnostics by ISO 7638 socket (EBS)	Steel parts shot blasted, with KTL System and high-quality surface coating; axles incl. wheel hubs coated black; underrun protection and light supports coated white for safety reasons; wheels silver with high-quality paint finish; accessories black or galvanized; laminate coating coloured in RAL 9010 white; reflective outline marking according to ECE-R48
Lights according to UN ECE reg. no. 48; 2 x 7-pin socket DIN ISO 1185/3731; contouring lights, number plate lights and side marker lights in LED; multi function rear lights incl. rear fog light and 1 reversing light	
Plastic fuel tank, approx. 240 litres (when equipped with cooling unit); closed pallet box for 36 Euro-pallets, 1 PVC tool box	
Low-noise alloy floor; strength acc. to DIN EN 283; for floor loadings up to 5.500 kg stacker-truck axle load; reinforced at rear	