

3-axle cooling trailer with ATP/FRC certificate – side and rear view

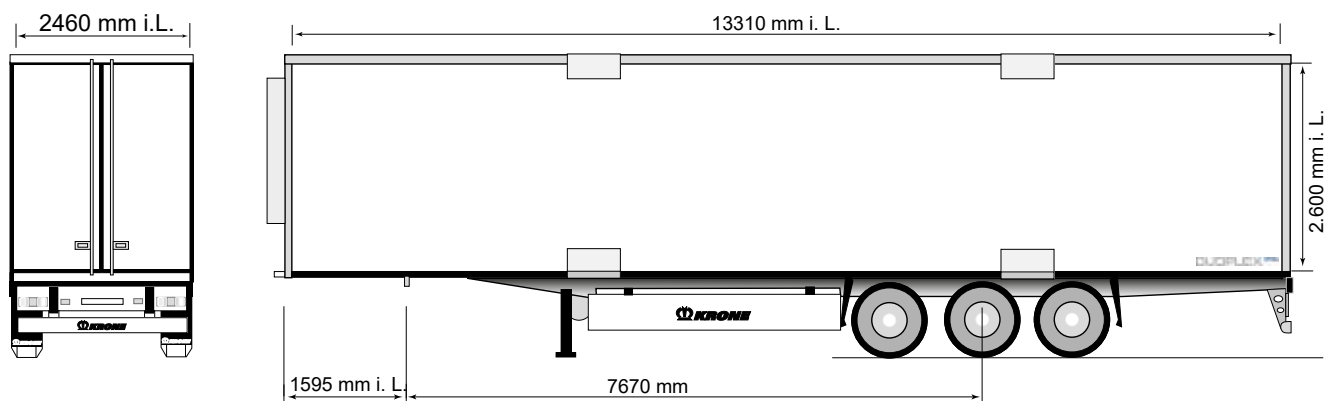

Technical data	
Type:	SDR 27 eLH4-S
King Pin load:	14,000 kg
Axle load (technically possible):	27,000 kg
Perm. total weight (technically possible):	41,000 kg
Tare weight (without cooling unit):	approx. 7,520 kg
Coupling height unloaded:	1,150 mm
Axle stand height	1,130 mm
Axle spread:	1,410 / 1,310 mm
Internal length:	13,310 mm
Internal width:	2,460 mm
Internal height:	2,600 mm

(Dimensions and weights for standard units)

Are you already familiar with Krone's services?



- SPARE PARTS
- TELEMATICS
- FAIR CARE
- MOBILITY
- SERVICE LOCATOR

Find out more about:
www.krone-trailer.com/english/service

Technical description:	
<p>Continuous chassis construction with double T longitudinal beams and cross members; rear traverse with diagonal reinforcements, neck height: 10 mm; Huckepack version for pocket wagons incl. 4 gripper edges; axle stand height, HK profile and pocket wagon compatibility on request</p>	<p>Box in thermal bridge free panel construction, panels on both sides with steel outer skin, painted outside, inside PVC coated; 100 % CFC-free foam</p>
<p>Mechanically operated landing legs, 2 x 12 tonnes capacity, leveling foot half round with base plate</p>	<p>Roof as sandwich panel; LED ceiling lamps, door contact switch for ceiling lamps</p>
<p>Low-maintenance axles with air suspension and disc brakes (430 mm), offset 120; raise/lower valve (1 valve) incl. auto reset</p>	<p>Front wall as sandwich panel; floor connection with chafe-resistant alloy kick strip; 4 vertical alloy distance profiles for optimal air flow; front wall with bolted protection wall</p>
<p>Tyres: 6 x 385/65 R 22.5, brand: Krone choice</p>	<p>Side wall as sandwich panel; floor connection with chafe-resistant kick strip; Protective fittings on the outside made of V2A in the area of the gripper edges (top and bottom)</p>
<p>Spare wheel carrier as an option</p>	<p>Container type double rear doors with 3 alloy hinges per door; sealing system with outside dust protection, V2A portal frame with airlock sealing edge above and below; two outer one-hand comfort closure door lockings; chafe resistant alloy kick strips inside die doors; door retainer</p>
<p>Wheel cover with splash guard according to EC regulations; Mud flap foldable on last axle</p>	<p>Air duct; ATP-certificate; load securing certificate Code XL; cooling unit on request for extra charge</p>
<p>Brake system according to ECE R 13 (including vehicle stabilising system); spring parking brake; 2S/2M EBS system, 2 sensors on one axle, diagnostics by ISO 7638 socket (EBS)</p>	<p>Steel parts shot blasted, KTL-primed and with high quality surface coating; axles incl. wheel hubs in KTL black; underrun protection and light supports coated white for safety reasons; wheels silver with high-quality finish; accessories black or galvanized; laminate coating coloured in RAL 9010 white; reflective outline marking according to ECE-R48</p>
<p>Lights according to UN ECE reg. no. 48; 2 x 7-pin socket DIN ISO 1185/3731; contouring lights, number plate lights and side marker lights in LED; multi function rear lights incl. rear fog light and 1 reversing light</p>	
<p>Plastic fuel tank, approx. 240 litres (when equipped with cooling unit)</p>	
<p>Low-noise alloy floor; strength acc. to DIN EN 283; for floor loadings up to 5.500 kg stacker-truck axle load; reinforced at rear</p>	