

Mega Liner

» Type: SDP 27 eLG4-CS

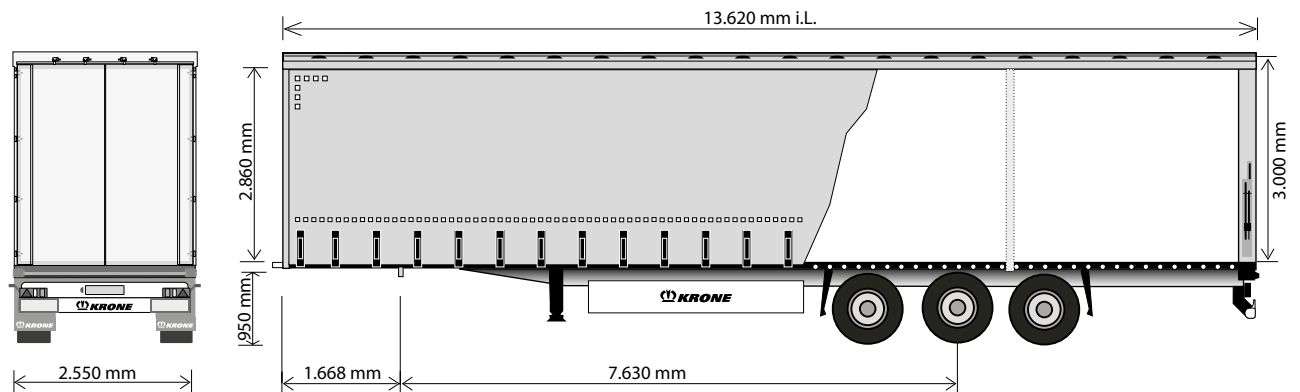

Mega Liner with hydraulic lifting roof



Technical data:

Type:	SDP 27 eLG4-CS
King pin load:	12,000 kg
Axle load (technically possible):	27,000 kg
Allowable gross weight (technically possible):	39,000 kg
Tare weight:	approx. 6,500 kg
Payload (technically possible):	approx. 32,500 kg
Axle spread:	1,310 / 1,310 mm
Neck height:	80 mm
5th wheel height:	950 - 1,160 mm
Side access length:	13,620 mm
Side access width:	2,480 mm
Side access height:	2,610 - 2,910 mm
Suitable internal height for automotive boxes:	3,000 mm

(Dimensions and weights for standard units)

Are you already familiar with Krone's services?



Find out more about:
www.krone-trailer.com/english/service

Technical description:

Multi Lock side rave including load securing positions every 100 mm	Alloy cant rail, continuous, for support of sliding curtain and sliding posts; EDSCHA sliding roof with plastic joints, height 175 mm, grade 0 mm, suitable for automotive boxes according to DIN 15155; Lifting roof, hydraulic, liftable 500 mm at 4 corner posts Adjustable driving height, front, lowering device from basic position 150 mm (in 50 mm steps), reduced lift: 350 mm Adjustable driving height, rear, lowering device from basic position 100 mm (in 50 mm steps), reduced lift: 400 mm; 4 sets of wooden planks; diagonal roof spanning
2 mechanically operated landing legs, 2 x 12 tonnes capacity, half round with base plate	Front wall bolted with solid corner posts; lateral restricted through loading; Front wall reinforced with plywood inner skin; quick release for side curtains on front wall; retainer for curtain cord
Low-maintenance axles with air suspension and disc brakes (430 mm), offset 120; raise/lower valve incl. auto reset valve	Container rear doors including bolted steel frame, integrated double door looks and concealed door hinges; roof header hinged and movable; clamping device for tarpaulin with ratchet at the rear frame
Tyres: 6 x 435/50 R 19.5, brand: Krone choice	3 pairs of side posts, symmetrical, Plank pockets for posts
Spare wheel carrier as an option	Delta shaped rubber profiles at rear; delta steel buffers at rear; load security certificate according EN 12642 Code XL
Wheel covering according to EC-regulations; Spray suppression according to EC-guidelines	1 PVC curtain with full lengths vertical reinforcements, top with rollers for sliding curtains, bottom with tensioners, curtain tensioner out of stainless steel
Brake system according to ECE R 13, including vehicle stabilising system; spring parking brake; 2S/2M EBS system, 2 sensors on one axle with RSS, diagnostics by ISO 7638 socket (EBS)	Steel parts shot blasted, with KTL primer and high-quality surface coating (standard painting single-colour); axles incl. wheel hubs painted black; under-run protection and light panel coated white for safety reasons; wheels silver with high-quality paint finish; reflective outline marking according to ECE-R48
Lights according to UN ECE reg. no. 48; 24 volts lighting system with 2 x 7-pin socket DIN ISO 1185/3731; front and rear marker lights; two multi-function rear lights incl. rear fog light and reversing lights; contouring lights, number plate lights and side marker lights in LED	
30 mm thick, phenolic coated plywood floor, cut surfaces fully waterproofed and sealed. Strength acc. to DIN EN 283; for floor loadings up to 7,000 kg stacker-truck axle load	



Fahrzeugwerk Bernard KRONE GmbH & Co. KG
 Bernard-Krone-Straße 1, 49757 Werlte, GERMANY
 Phone: +49 (0) 5951 209-0, Fax: +49 (0) 5951 209-98-268

Subject to modifications!
 VF/Beu issue 03/2020