

# Mega Liner 50 mm Neck

» Type: SDP 27 eLMG-CS

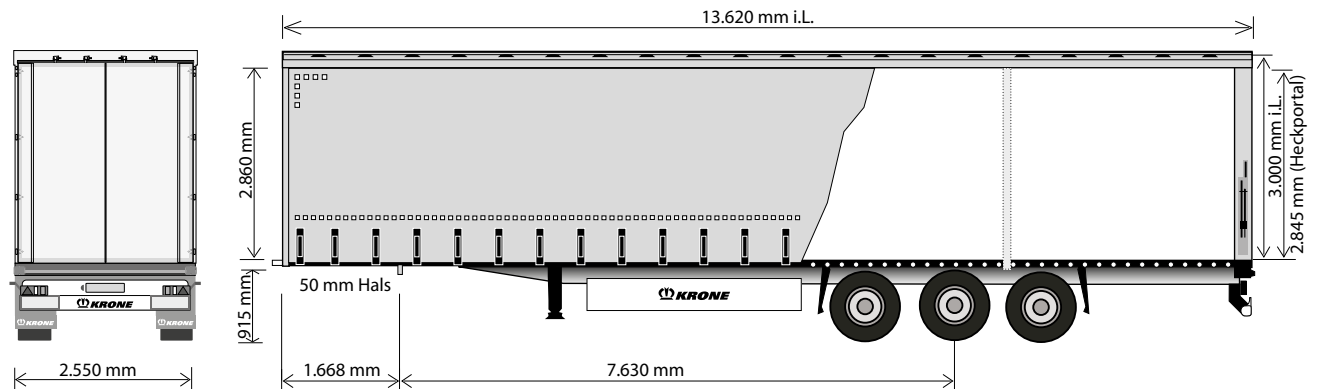

## Mega Liner, 50 mm neck, with hydraulic lifting roof



### Technical data:

Type:	SDP 27 eLMG-CS
King pin load:	12,000 kg
Axle load (technically possible):	27,000 kg
Allowable gross weight (technically possible):	39,000 kg
Tare weight:	approx. 6,900 kg
Payload (technically possible):	approx. 32,100 kg
Axle spread:	1,310 / 1,310 mm
Neck height:	50 mm
5th wheel height:	915 mm
Side access length:	13,620 mm
Side access width:	2,480 mm
Side access height:	2,860 mm
Suitable internal height for automotive boxes:	3,000 mm

(Dimensions and weights for standard units)

### Are you already familiar with Krone's services?



Find out more about:  
[www.krone-trailer.com/english/service](http://www.krone-trailer.com/english/service)

### Technical description:

Multi Lock side rave including load securing positions every 100 mm	Alloy cant rail, continuous, for support of sliding curtain and sliding posts; EDSCHA sliding roof with plastic joints, height 175 mm, grade 0 mm, suitable for automotive boxes according to DIN 15155; Lifting roof, hydraulic, liftable 500 mm at 4 corner posts Adjustable driving height, front, lowering device from basic position 100 mm (in 50 mm steps), reduced lift: 350 mm Adjustable driving height, rear, lowering device from basic position 100 mm (in 50 mm steps), reduced lift: 400 mm; 4 sets of wooden planks; diagonal roof spanning
2 mechanically operated landing legs, 2 x 12 tonnes capacity, half round with base plate	Front wall bolted with solid corner posts; lateral restricted through loading; Front wall reinforced with plywood inner skin; quick release for side curtains on front wall; retainer for curtain cord
Low-maintenance axles with air suspension and disc brakes (430 mm), offset 120; raise/lower valve incl. auto reset valve	Container rear doors including bolted steel frame, integrated double door looks and concealed door hinges; roof header hinged and movable; clamping device for tarpaulin with ratchet at the rear frame
Tyres: 6 x 445/45 R 19.5, brand: Krone choice	3 pairs of side posts, symmetrical, Plank pockets for posts
Spare wheel carrier as an option	Delta shaped rubber profiles at rear; delta steel buffers at rear; load security certificate according EN 12642 Code XL
Wheel covering according to EC-regulations; Spray suppression according to EC-guidelines	1 PVC curtain with full lengths vertical reinforcements, top with rollers for sliding curtains, bottom with tensioners, curtain tensioner out of stainless steel
Brake system according to ECE R 13, including vehicle stabilising system; spring parking brake; 2S/2M EBS system, 2 sensors on one axle with RSS, diagnostics by ISO 7638 socket (EBS)	Steel parts shot blasted, with KTL primer and high-quality surface coating (standard painting single-colour); axles incl. wheel hubs painted black; under-run protection and light panel coated white for safety reasons; wheels silver with high-quality paint finish; reflective outline marking according to ECE-R48
Lights according to UN ECE reg. no. 48; 24 volts lighting system with 2 x 7-pin socket DIN ISO 1185/3731; front and rear marker lights; two multi-function rear lights incl. rear fog light and reversing lights; contouring lights, number plate lights and side marker lights in LED	
Pallet stop in the 1st post area, both sides, 30 mm high	
30 mm thick, phenolic coated plywood floor, cut surfaces fully waterproofed and sealed. Strength acc. to DIN EN 283; for floor loadings up to 7,000 kg stacker-truck axle load	



Fahrzeugwerk Bernard KRONE GmbH & Co. KG  
 Bernard-Krone-Straße 1, 49757 Werlte, GERMANY  
 Phone: +49 (0) 5951 209-0, Fax: +49 (0) 5951 209-98-268

Subject to modifications!  
 VF/Beu issue 03/2020