

Profi Liner 4 in sliding roof design, TIR execution

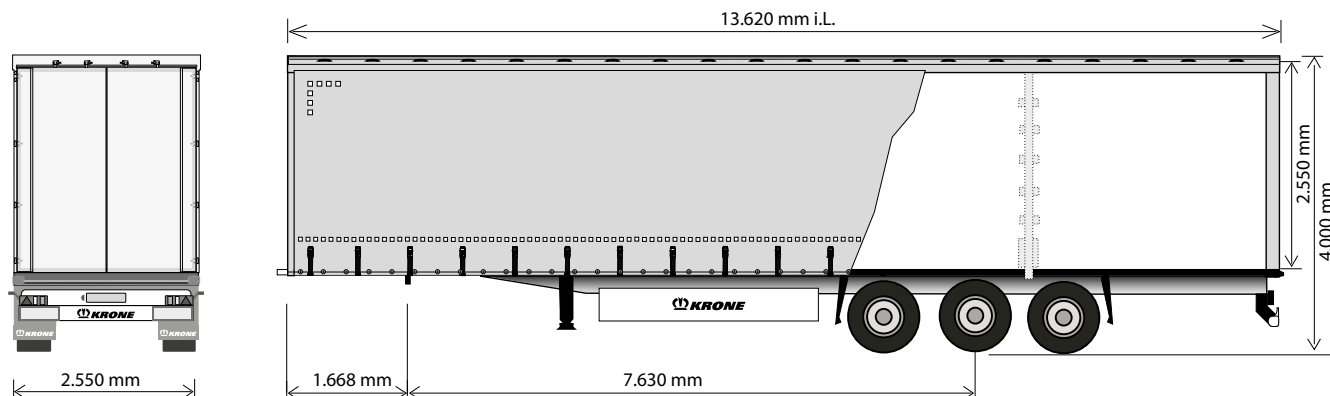

Technical data:	
Type:	SDP 27 eLB4-CT
King pin load:	12,000 kg
Axle load (technically possible):	27,000 kg
Allowable gross weight (technically possible):	39,000 kg
Tare weight:	approx. 6,290 kg
Payload (technically possible):	approx. 32,710 kg
Axle spread:	1,310 / 1,310 mm
Neck height:	125 mm
5th wheel height:	1,040 - 1,250 mm
Side access length:	13,620 mm
Side access height:	2,600 - 2,700 mm
Side access width:	2,480 mm
Turning radius:	2,040 mm

(Dimensions and weights for standard units)

Are you already familiar with Krone's services?

Find out more about:
www.krone-trailer.com/english/service

Technical description:	
Smooth side rave, with curtain cramps for Customs seal and reach protection on side rave 14 pairs of lashing rings integrated in the floor	Alloy cant rail, continuous, for support of sliding curtain and posts, EDSCHA sliding roof in TIR execution, Roof movable to the front; 4 sets of wooden planks; diagonal roof spanning
2 mechanically operated landing legs, 2 x 12 tonnes capacity, half round with base plate	Front wall bolted with solid corner posts; lateral restricted through loading; Front wall reinforced with plywood inner skin; quick release for side curtains on front wall, secured with cover plate and customs cord; retainer for curtain cord
Low-maintenance axles with air suspension and disc brakes (430 mm), offset 120; raise/lower valve incl. auto reset valve	Container rear doors including bolted steel frame, integrated double door locks and concealed door hinges; roof header hinged and movable; clamping device for tarpaulin with ratchet at the rear frame; ratchet curtain tensioner secured with cover plate and customs cord
Tyres: 6 x 385/65 R 22.5, brand: Krone choice	3 pairs of side posts, symmetrical, plank pockets for posts
Wheel covering according to EC-regulations; Spray suppression according to EC-guidelines	Delta shaped rubber profiles at rear; delta steel buffers at rear; customs seal (TIR LINER) for upper structure; 2 TIR-signs foldable (1 front/1 rear) load security certificate according EN 12642 Code XL
Spare wheel carrier as an option	1 PVC curtain with full length vertical reinforcements, Roof curtain to meet customs regulations with wire rope in the hem; top with rollers for sliding curtains, bottom with tensioners and eyelets for customs seal, curtain tensioner out of stainless steel; Plastic joints for rollers according to customs regulations - TIR cord fitted
Brake system according to ECE R 13, including vehicle stabilising system; spring parking brake; 2S/2M EBS system, 2 sensors on one axle with RSS, diagnostics by ISO 7638 socket (EBS)	Steel parts shot blasted, with KTL primer and high-quality surface coating (standard painting single-colour); axles incl. wheel hubs painted black; under-run protection and light panel coated white for safety reasons; wheels silver with high-quality paint finish; reflective outline marking according to ECE-R48
Lights according to UN ECE reg. no. 48; 24 volts lighting system with 2 x 7-pin socket DIN ISO 1185/3731; front and rear marker lights; two multi-function rear lights incl. rear fog light and reversing lights; contouring lights, number plate lights and side marker lights in LED	
30 mm thick, phenolic coated plywood floor, cut surfaces fully waterproofed and sealed. Strength acc. to DIN EN 283; for floor loadings up to 7,000 kg stacker-truck axle load	