

# Dry Liner

» Type: SDK 27 eLB4.1-STG

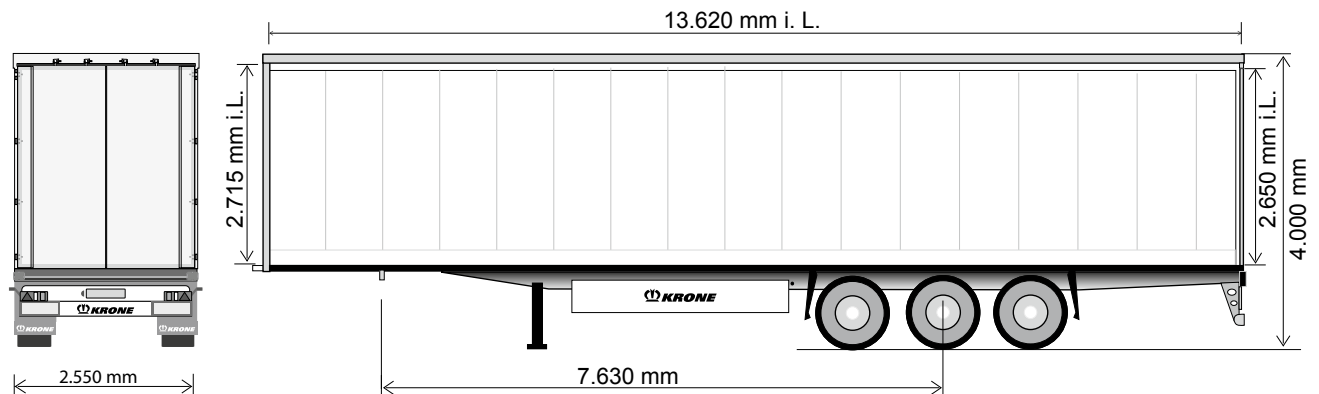

## 3-axle box-type semitrailer with steel cassette side walls



### Technical Data:

Type:	SDK 27 eLB4.1-STG
King pin load:	12,000 kg
Axle load (technically possible):	27,000 kg
Perm. total weight (technically possible):	39,000 kg
Tare weight:	approx. 7,890 kg
Payload (technically possible):	approx. 31,110 kg
Axle spread:	1,310 / 1,310 mm
Neck height:	100 mm
5th wheel height:	1,150 mm
Internal length:	13,620 mm
Internal height:	2,715 mm
Internal width:	2,480 mm
Through loading height in the rear frame:	2,650 mm

Dimensions and weights for standard units)

### Are you already familiar with Krone's services?



Find out more about:  
[www.krone-trailer.com/english/service](http://www.krone-trailer.com/english/service)

### Technical Description

2 mechanically operated landing legs, 2 x 12 tonnes capacity, half round with base plate	Closed box superstructure of steel cassettes
Low-maintenance axles with air suspension and disc brakes (offset 120); raise/lower valve (1 valve) incl. auto reset valve	Side walls made of galvanized steel cassettes; above kick strips with recesses; side walls inside with key hole profile; Front wall out of trapezium shaped steel plates, with 9 mm thick plywood on inner, approx. 1,250 mm height
Tyres: 6 x 385/65 R 22.5, brand: Krone choice	internal forklift protection, at side walls, approx. 350 mm high , 250 mm at front wall
Wheel covering according to EC-regulations; Spray suppression according to EC-guidelines	6 LED-flush ceiling lights, integrated in roof laterally, offset; Light switch at rear, right side under the floor; 2 ventilation gates on each side wall
Spare wheel carrier as an option	Profiled roof with steel trapezium sheets, thickness: 25 mm
Brake system according to ECE R 13, including vehicle stabilising system; spring parking brake; 2S/2M EBS system, 2 sensors on one axle with RSS, diagnostics by ISO 7638 socket (EBS)	Rear wall designed as steel container rear door with replaceable door sealing, (internal width approx. 2,460 mm); Double door locks for container door, integrated door locks (flat out side surface), operated underneath the door
Lights according to UN ECE reg. no. 48; 24 volts lighting system with 2 x 7-pin socket DIN ISO 1185/3731; front and rear marker lights; two multi-function rear lights incl. rear fog light and reversing lights; contouring lights, number plate lights and side marker lights in LED	Load security certificate according to EN 12642 Code XL
30 mm thick, phenolic coated plywood floor, cut surfaces fully waterproofed and sealed. Strength acc.to DIN 283; for floor loadings up to 7,000 kg stacker-truck axle load	Steel parts shot blasted, with KTL primer and high-quality surface coating (standard painting single-colour); axles incl. wheel hubs painted black; under-run protection and light panel coated white for safety reasons; wheels silver with high-quality paint finish; reflective outline marking according to ECE-R48



Fahrzeugwerk Bernard KRONE GmbH & Co. KG  
 Bernard-Krone-Straße 1, 49757 Werlte, GERMANY  
 Phone: +49 (0) 5951 209-0, Fax: +49 (0) 5951 209-98-268

Subject to modifications!  
 VF/Beu issue 05/2022