

Mega Box Carrier

» Type: AZW 18 zLTB7

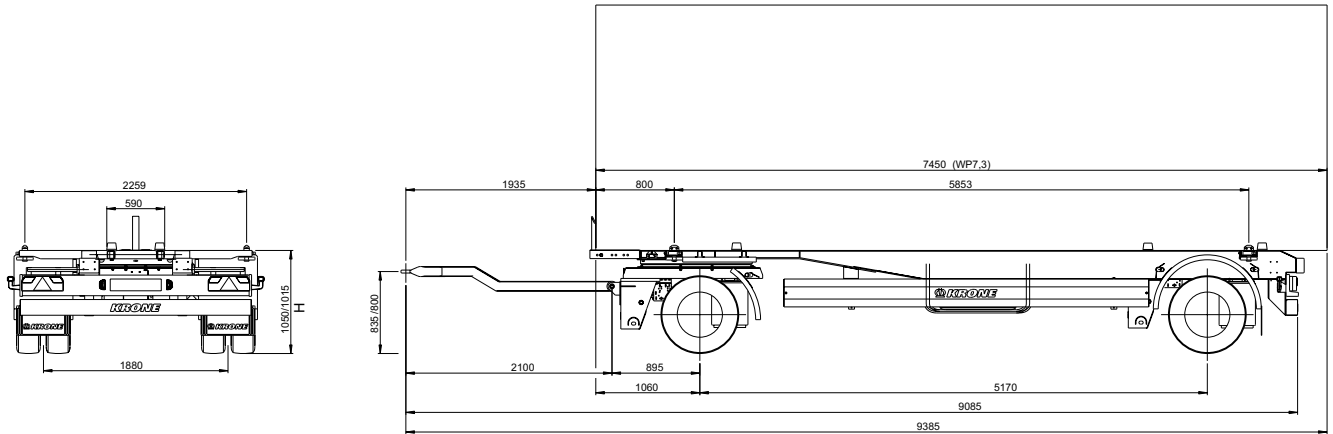

Chassis for transporting swap bodies, according to DIN EN 284, size C715, C745 (with additional stop also C782) and containers according to ISO 668/1496, size 20'



Height H (in mm)				
Tyres	Driving position		unloaded lowered	loaded lifted
	unloaded	loaded		
235/75 R 19.5	1,055	1,020	990	1,350
245/70 R 17.5	1,055	1,020	990	1,350
215/75 R 17.5	1,045	1,015	980	1,345

Technical data	
Type:	AZW 18 zLTB7
Allowable gross weight:	18,000 kg
Tare weight, approx.:	3,000 kg
Payload (without swap body):	15,000 kg
Axle spread distance:	5,170 mm
Total length (centre draw bar eye), approx.:	9,085 mm
Draw bar length:	2,100 mm
Distance between container lockings:	5,853 mm
Distance front stop to first locking:	800 mm
Landing height:	1,020-1,320 mm

(Dimensions and weights for standard units)

Technical description
Double T-longitudinal beams and cross members in welded construction. Neck height: 85 mm, 4 container lockings on 20' basis; removable tunnel central rollers, according to „BDF-Lastenheft“; Protection at rear with large rubber buffer; Rear bumper and side guard according to EC-regulation
Stop at front for swap body 7,3 - removeable for swap body 7; Length of chassis designed for swap body 7 flush with rear
Low maintenance steering pivot and draw bar with rubber baring and retaining spring; towing eye 40 mm; drawbar 150 mm cranked
Low-maintenance axles with air suspension and drum brakes (300 x 200 mm for 17.5" rim); including raise and lower valve, 2 valves, total hub 430 mm; rims centre nave
Tyres: 8 x 235/75 R 17.5, brand Krone choice
Spare wheel carrier as an option
Wheel covering according to EC-regulations; Mud guard, 3 black plastics segments at front, rear as half shell with mud flaps; Spray suppression according to EC guideline
Brake system according to EC-regulations; Spring parking brake; Release device for front axle; EBS-braking system, 4S/3M, 4 sensors on 2 axles; EBS-Modulator with electronic stability system; carrier for additional air tank; Diagnostics by ISO7638 plug connection (EBS supply cable)
Lights according to UN ECE Rg.Nr. 48; 24 volts lighting system, with two multi-function rear lights acc. to EC incl. rear fog light and reversing lights; 7-channel-power plug at front for additional uses; 2 contouring lights with rubber arm in LED; side marker lights in LED
Steel parts shot blasted, with KTL primer and high-quality surface coating (standard painting single-colour); axles incl. wheel hubs, drawbar and chassis painted black; underrun protection and light panel coated white for safety reasons; wheels silver with high-quality paint finish; reflective line marking according to ECE-R48

