

Insulated Cool Box in double deck design

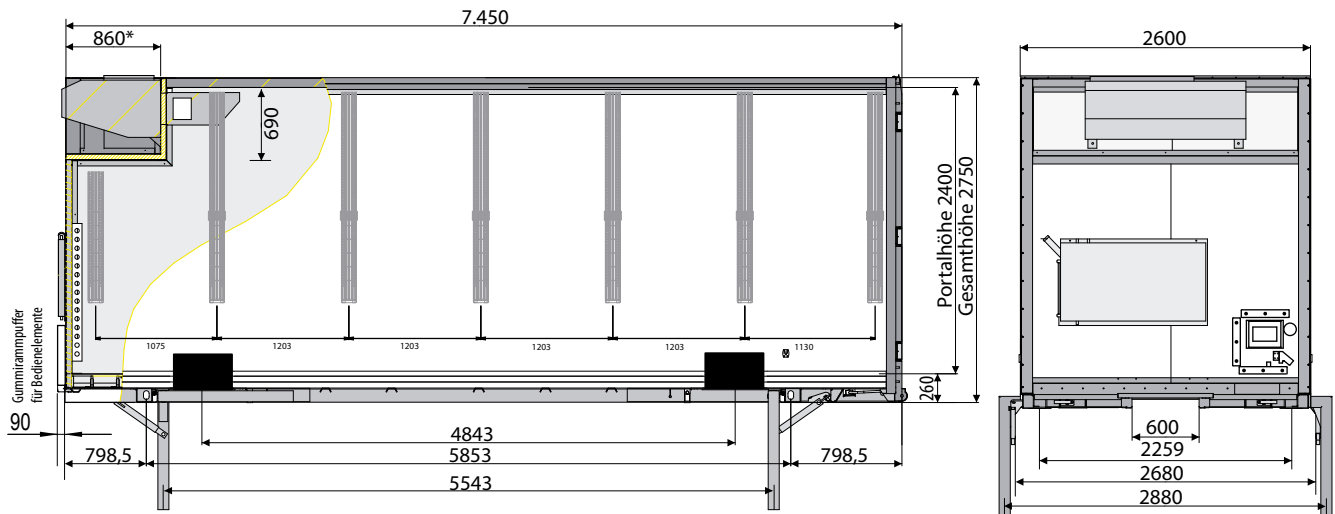

*= depending on the fitted fridge engine

Caution: Buffers for controls will extend the box

Front view with cooling unit and tank

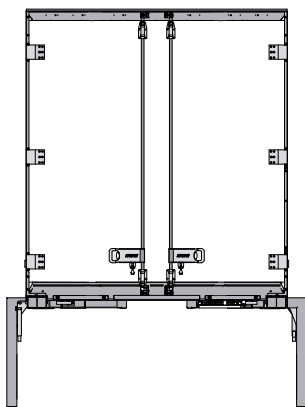

Technical description

260 mm thick floor group including floor plates; longitudinal beams with crossbars in welded construction with tunnel; 4 container corner fittings based on 20'; symmetrical overhang; tank and buffer will extend the overhang

4 grapple pockets; Pull out ladder at rear

4 lateral extendable / foldable landing legs, with double securing

Low-noise alloy floor, PIEK qualified; floor load capacity tested acc. to EN 283; reinforced at rear

Box thermal bridge free panel construction, panels on both sides with steel, outer skin; 100 % CFC-free

Roof sandwich panel with steel outer skin; ceiling lights as an option

Front wall as sandwich panel with front wall niche, including reinforcement and cut outs for installation of either Carrier or Thermo King cooling unit.

Side walls in front continuous

Side wall as sandwich panels with steel outer layer, exterior painted, interior PVC coated; base tube joined on front and both sides, 300 mm aluminium kick strip fully welded to floor; Protection at grapple pocket area; 7 sets of double deck rails, type Airline, inserted into side walls, full length 1.600m from the roof; 12 Double deck bar, capacity approximately 10 KN per double deck bar, height 90 mm; Pallet security on the last double deck load lock bar

Container type double rear doors, 3 piece aluminium hinges on each door half; quick replacement door sealing system with outside dust protection, one pair of stainless steel door lock rods. Door catch designed as T-hook; 2 door lockings operated by hand, rear; aluminium kick strips on inner side of rear doors, 285 mm high

ATP-Certificate - IR; load security certificate according to EN 12642 Code XL; grip handle for rear access; cooling unit by request for extra charge

Steel parts shot blasted, with KTL base coat and high-quality surface coating; corner protections and crane brackets different colour

Technical data

Type:	WR 7,3 DS	WR 7,7 DS
Perm, total weight:	16,000 kg	16,000 kg
Tare weight (without cooling unit) approx.:	3,640 kg	3,800 kg
Internal length:	7,240 mm	7,610 mm
Internal width:	2,460 mm	2,460 mm
Overall length:	7,450 mm	7,820 mm
Thickness Floorgroup (incl, Floor):	260 mm	260 mm
Internal height:	2,400 mm	2,400 mm
Corner height:	2,750 mm	2,750 mm
Landing height:	1,320 mm	1,320 mm

(Dimensions and weights for standard units)