

# Planen Box

Typ: WP 7,3 LF5- BW

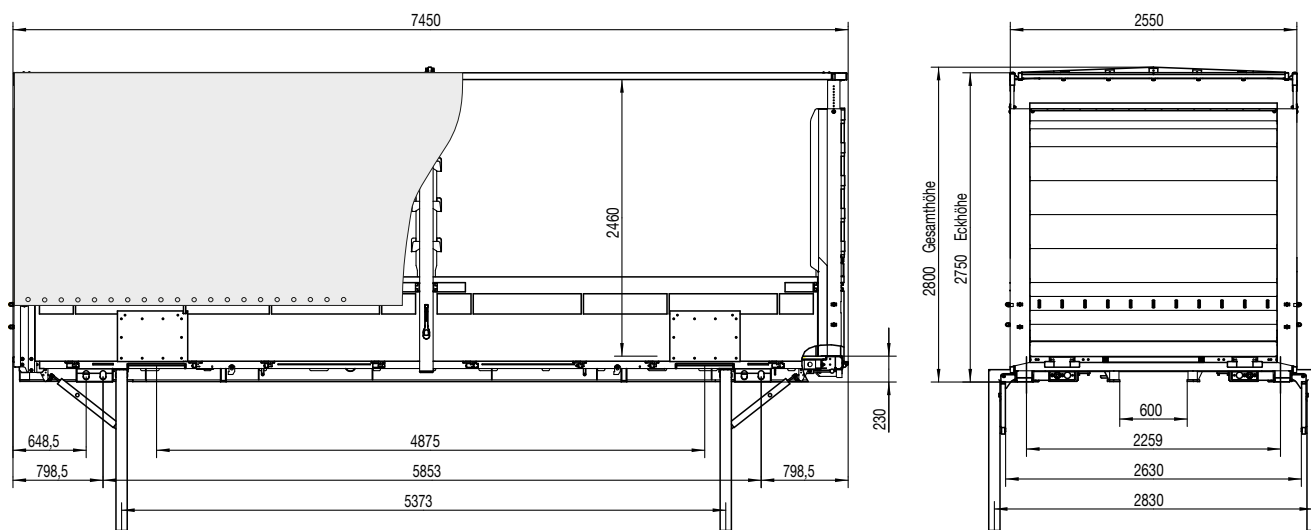

Swap Body with tarpaulin and roof bows and with side walls (front- and rearview)



Rear view with small double wing door

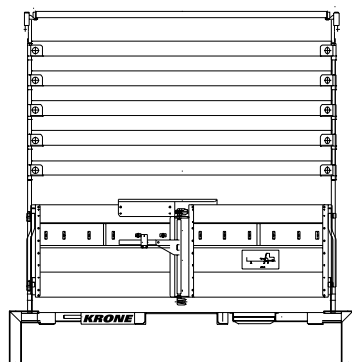

## Technical description:

230 mm thick floor group including floor plates; rectangular longitudinal beams and cross members including side rave in welded construction with tunnel. 4 container corner fittings based on 20', symmetrical overhang

4 grapple pockets; Pull out ladder at rear; Multi Lock side rave including load securing positions every 100 mm

4 lateral extendable / foldable landing feet, 2-fold locking; Landing leg support

27 mm thick plywood floor, fully waterproofed and sealed, resistance test according to DIN EN 283, for floor loadings up to 5.460 kg forklift axle load

fixed hamburger roof, outer beams 60 mm designed as slide rail for moveable stanchions; gradient 50 mm centered with 7 cross members; 4 sets of wooden planks (96 x 25 mm)

Front wall smooth with steel cassettes (galvanized), inside with 12 mm plywood covering in total height; 2 lashing points fixed inside on both sides, fixed at height approx. 1,000 mm

Aluminium rear wall as small double wing door, 750 mm height

2 drop sides on each side, 750 mm height, hinged and removable, tension rod; crimp profile in drop sides; without drop side protection above grapple pockets

1 pair of side posts with rollers, moveable in cant rail; 4 sets of plank pockets in stanchions

Steel side guard horizontally fixed at rear profile; with customs seal (cramps on corner posts); flat steel forklift protection; load security certificate according EN 12642 Code XL

1 row of customs curtain cramps; PVC curtain according to railway regulations; light rail in roof; opening division with vertical closure strap, corner opening division on the side of the trailer, front and rear.

Steel parts are shot blasted, KTL-primer coated and powder coated; Series painting 1 color; container corner fittings and grapple pockets in contrasting color

Technical data:	Standard	Option
Type:	<b>WP 7,3 LF5</b>	WP 7,7 LF5
Perm, total weight:	<b>16.000 kg</b>	16,000 kg
Tare weight, approx.:	<b>2,480 kg</b>	2,620 kg
Internal length:	<b>7,300 mm</b>	7,670 mm
Internal width:	<b>2,480 mm</b>	2,480 mm
Total length:	<b>7,450 mm</b>	7,820 mm
Height of floor assembly, incl. floor:	<b>230 mm</b>	230 mm
Side acces height:	<b>2,460 mm</b>	2,460 mm
Corner height:	<b>2,750 mm</b>	2,750 mm
Front/rear overhang:	<b>648,5/798,5 mm</b>	983,5 mm
Landing height:	<b>1,320 mm</b>	1,320 mm

(Dimensions and weights for standard units)



Fahrzeugwerk Bernard KRONE GmbH & Co. KG  
Bernard-Krone-Straße 1, 49757 Werlte, GERMANY  
Phone: +49 (0) 5951 209-0, Fax: +49 (0) 5951 209-98-268

Subject to modifications!  
VF/Beu issue 10/2014