



TYRE MANUAL FOR COMMERCIAL VEHICLES

Tyres are technically complex products. Our manual helps you find answers to your questions about truck tyres.



KRONE COMMERCIAL VEHICLE SE

 Carbon Court | Peckfield Business Park | Micklefield | UNITED KINGDOM

 +44 1132 87 8819

 tyre-support@krone.de

 www.krone-trailer.com







Tyre manual for commercial vehicles

CONTENTS

Sidewall marking	2-3
Size designation	4
Speed index	4
Load index	5
Terminology and structure	6-7
Dimensions	8-9
Winter tyres in Europe	10-16
Care and maintenance	18-21
Marking and energy label	22-27
TYRE:COMFORT KT231 (385/65R22,5)	28
KRONE COMFORT:TYRE (385/65R22,5)	29
KRONE ECO:TYRE (385/65R22,5)	30
KRONE R:TYRE T3001 (385/65R22,5)	31
KRONE PRIME:TYRE (385/55R22,5)	32
KRONE COMFORT:TYRE (385/55R22,5)	33
KRONE ECO:TYRE (435/50R19,5)	34
KRONE PRIME:TYRE KT2 (435/50R19,5)	35
KRONE PRIME:TYRE KT2 (445/45R19,5)	36

Sidewall marking

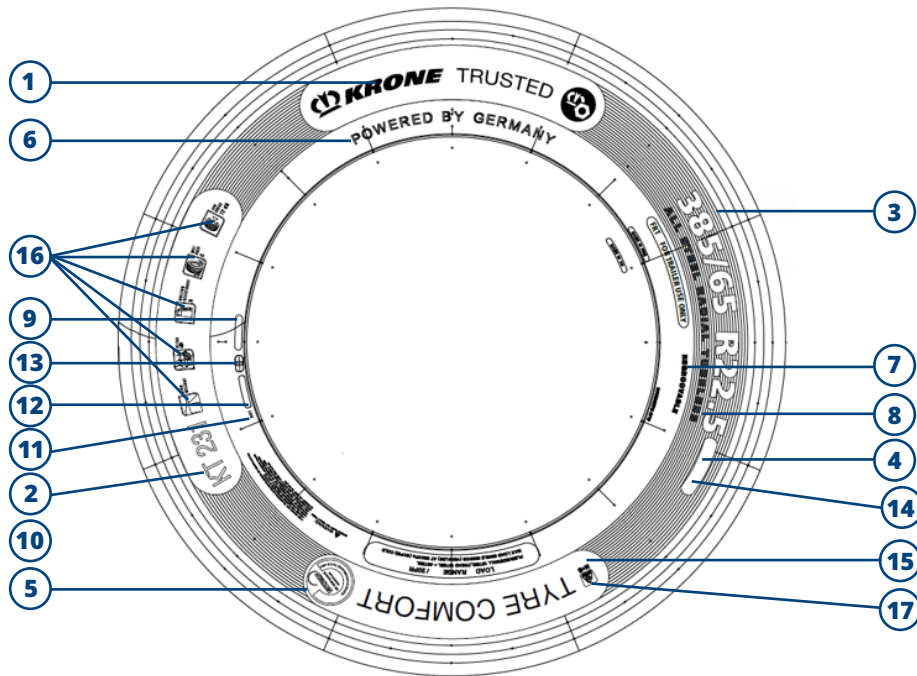

1 Brand name

2 Profile designation

3 Size designation

385 = Tyre width in mm
 65 = Cross-section ratio
 (65% sidewall height
 to width)
 R = Radial construction
 22.5 = Rim diameter
 in inches

4 Operating code

160 = Load index for
 single arrangement
 K = Code letter for the
 reference speed

5 TÜV stamp

All products and production
 facilities are tested and
 certified by TÜV Nord.

6 Powered by Germany

Development with German
 expertise

7 Regroovable

The tyre is designed for
 regroovable.

8 Tubeless

Tyres without inner tubes

9 Tube Type

Tyres with inner tubes

10 ECE marking

E = Type approval authority
 E4 = Country code for the country
 in which the E marking
 was approved (E1 = DE;
 E2 = FR; E4 = NL; E11 = EN)

11 DOT marking

The tyre complies with FMVSS 119
 regulations in the USA

12 DOT code

Identification number for manufacturer,
 tyre size and tyre design

13 Date of manufacture

Week of production (digits 1+2) and
 Year of production (digits 3+4)

14 Double identification

Alternative load and speed index for
 simultaneous use as front axle or trailer
 tyres

15 M+S

Marking for winter-ready tyres
 (mud + snow)

16 Eco icons

High Mileage: High mileage

Energy-Efficient: Fuel-efficient

Low Noise: Low rolling noise

Clean Air: Produced with green
 oil, retreadable to
 protect the environment

17 3PMSF icon

The **3 Peak Mountain Snow Flake**
 symbol indicates that the tyre meets the industry
 standard for winter tyres.

Size designation

The tyre size designation is located on the sidewall of the tyre and indicates the characteristics in terms of dimensions and design (R = radial or D = diagonal). In accordance with the ECE54 standard, an additional service index, also known as a dual index, is permitted, which is placed in a circle in the immediate vicinity of the base service index on the sidewall.

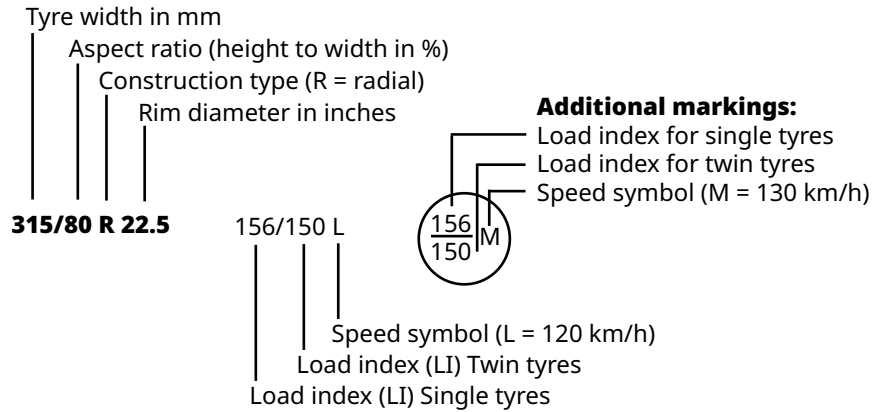

Speed index

The speed symbol indicates the maximum speed at which a tyre may be loaded at standard air pressure in accordance with the load index.

Symbol	Speed (km/h)
E	70
F	80
G	90
J	100
K	110
L	120
M	130
N	140
P	150
Q	160
R	170
S	180
T	190

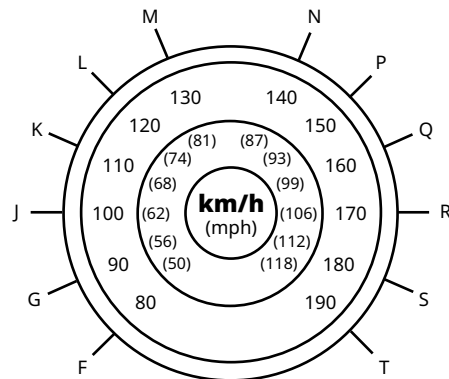

Load index

The load index (LI) indicates the maximum load capacity of a tyre in kilograms at standard air pressure and the maximum permissible speed. The load index is indicated by a letter or number.

LI	Kg	LI	Kg	LI	Kg
100	800	134	2.120	168	5.600
101	825	135	2.180	169	5.800
102	850	136	2.240	170	6.000
103	875	137	2.300	171	6.150
104	900	138	2.360	172	6.300
105	925	139	2.430	173	6.500
106	950	140	2.500	174	6.700
107	975	141	2.575	175	6.900
108	1.000	142	2.650	176	7.100
109	1.030	143	2.725	177	7.300
110	1.060	144	2.800	178	7.500
111	1.090	145	2.900	179	7.750
112	1.120	146	3.000	180	8.000
113	1.150	147	3.075	181	8.250
114	1.180	148	3.150	182	8.500
115	1.215	149	3.250	183	8.750
116	1.250	150	3.350	184	9.000
117	1.285	151	3.450	185	9.250
118	1.320	152	3.550	186	9.500
119	1.360	153	3.650	187	9.750
120	1.400	154	3.750	188	10.000
121	1.450	155	3.875	189	10.300
122	1.500	156	4.000	190	10.600
123	1.550	157	4.125	191	10.900
124	1.600	158	4.250	192	11.200
125	1.650	159	4.375	193	11.500
126	1.700	160	4.500	194	11.800
127	1.750	161	4.625	195	12.150
128	1.800	162	4.750	196	12.500
129	1.850	163	4.875	197	12.850
130	1.900	164	5.000	198	13.200
131	1.950	165	5.150	199	13.600
132	2.000	166	5.300		
133	2.060	167	5.450		

Terminology and structure

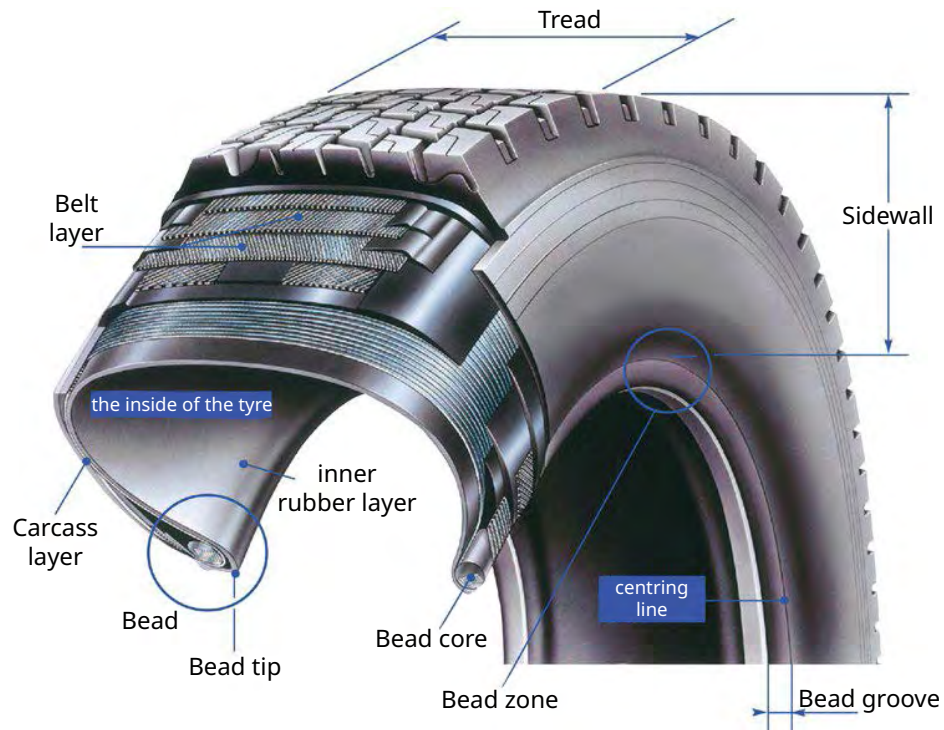

Tread: The tread is the top layer of the tyre and has a tread pattern (except for slicks). It provides traction and wear resistance and protects the underlying carcass. New lorry tyres have a tread depth of approximately 13.5 to 22 mm. The tread design and rubber compound influence properties such as grip, abrasion, rolling resistance and wet handling.

Belt: The tyre belt consists of several steel cord layers embedded in rubber and is largely inextensible. It stabilises the tread and protects the carcass from penetrating foreign objects.

Sidewall: The sidewall is a single layer of steel cord embedded in a flexible rubber layer, which protects the carcass from being penetrated by foreign objects. The tyre sidewall, also known as the flank or tyre flank, improves damping behaviour, thereby enhancing both comfort and handling, and can also protect against damage, for example by reinforcing bus tyres. All of the tyre's markings are located on the sidewall.

Tyre-shoulder: Transitional area between the sidewall and the tread.

Bead core: Ensures that the tyre fits securely on the rim by means of wire cores and surrounding carcass threads.

Inner liner: The sealing rubber layer inside the tyre replaces the inner tube and offers limited self-sealing against foreign objects. It is also called an inner tube, inliner or inner liner.

Carcass: Basic structure of the tyre, connecting the bead and belt. Usually consisting of rubberised textile cords, which together with the air pressure determine the load capacity.

Dimensions

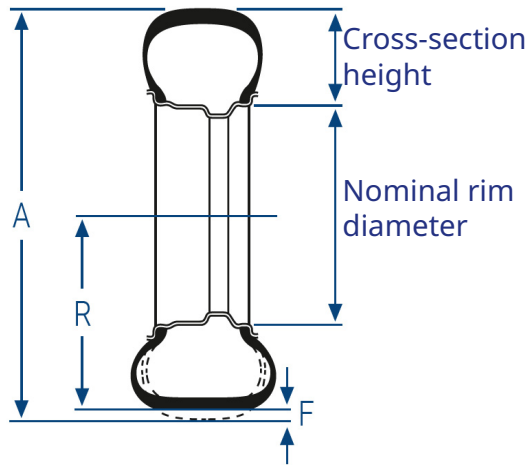

(A) Outer diameter:

Refers to the diameter of an inflated tyre mounted on the rim, measured to the outermost edge of the tread.

(R) Static radius:

The distance from the centre of the wheel to the road surface when the tyre is loaded to its maximum permissible load capacity.

(F) Spring deflection:

This is the reduction in tyre radius under normal load, i.e. the sinking of the axle. Tyres are designed for a specific degree of spring deflection; deviations shorten their service life.

Tyre width:

Measures the width of an inflated tyre in mm when mounted on a standard rim. It is also specified in the tyre size (e.g. **315/80 R 22.5**).

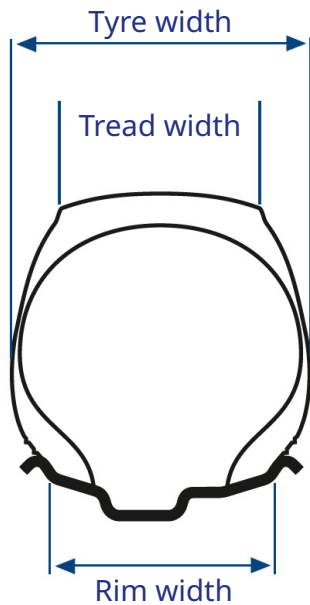

Tread width:

Specified in mm, this measures the width of the tread pattern.

Cross-section height:

The cross-section height is the distance between the bead seat and the outer tread of an inflated tyre.

Rim width:

The rim width measures the distance between the rim flanges and is also referred to as the rim mouth width.

(M) Minimum distance between rim centres:

This is a guideline value specified in mm that ensures the proper functioning of two tyres in twin mounting according to the ETRTO (European Tyre and Rim Technical Organisation) standard without chains.

Nominal rim diameter:

The nominal rim diameter measures the diameter of a rim from rim edge to rim edge. The value is included in the designation of the tyre and rim sizes and is usually given in inches ("). (e.g. 315/80 R **22.5**).

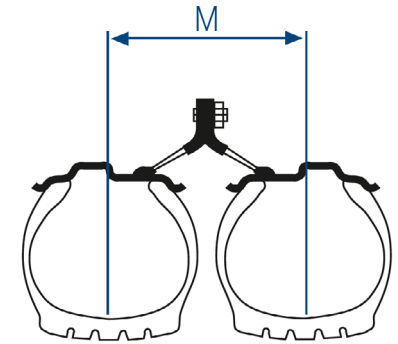

Winter tyres in Europe*

All tyres have M+S marking – in addition, all tyres designed for the drive axle also have 3PMSF marking. This guarantees that they meet the criteria for winter tyres in all European countries. Furthermore, the majority of our tyres for trailers and steering axles already have 3PMSF marking.

	Tyres	Snow chains	Profile
Albania	Winter tyres are recommended.	Carrying requirement from 1 November to 30 April; fitting may be required by traffic signs.	M+S 4 mm
Austria	Winter tyres are compulsory from 1 November to 15 April (buses until 15 March). For lorries with a gross vehicle weight of over 3.5 tonnes, winter tyres are only compulsory on the drive axle. From 1 October to 31 May, studded tyres are permitted for vehicles with a gross vehicle weight of less than 3.5 tonnes and a maximum axle load of 1.8 tonnes. Maximum speed 80/100 km/h.	Compulsory equipment for at least one drive axle from 1 November to 15 April, with exceptions for buses.	up to 3.5 t M+S 3 mm over 3.5 t M+S Tyres Drive axle Diagonal tyres 6 mm or Radial tyres 5 mm
Belgium	Spikes are permitted from 1 November to 31 March.	Use only permitted on snow and ice-covered roads.	1.6 mm
Bosnia and Herzegovina	Winter tyres are mandatory from 15 November to 15 April; alternatively, snow chains must be carried for at least one drive axle.	When using summer tyres, snow chains must be carried for at least one drive axle from 15 November to 15 April.	4 mm
Bulgaria	Minimum tread depth of 4 mm from 15 November to 1 March.	Must be carried from 1 November to 31 March; fitting may be required by traffic signs. Maximum speed 50 km/h.	4 mm

	Tyres	Snow chains	Profile
Croatia	Winter tyres are mandatory from 15 November to 15 April; alternatively, snow chains must be carried for at least one drive axle. For lorries with a maximum permissible weight of over 3.5 tonnes, winter tyres are only compulsory on the drive axle.	Summer tyres must be carried for at least one drive axle from 15 November to 15 April (snow chains are compulsory in the Lika/Gorski Kotar region).	up to 3.5 t 4 mm over 3.5 t drive axle M+S 4 mm
Cyprus	No information.	Installation may be required by traffic signs.	No information.
Czechia	Winter tyres are compulsory from 1 November to 31 March for vehicles with a maximum permissible weight of up to 3.5 tonnes only in winter conditions. For lorries over 3.5 tonnes, winter tyres are only compulsory on the drive axle.	Installation may be required by traffic signs.	up to 3.5 t M+S 4 mm over 3.5 t drive axle 6 mm
Denmark	Spikes are permitted from 1 November to 15 April.	Snow chains are permitted from 1 November to 15 April.	M+S 1.6 mm
Estonia	Winter tyres are mandatory for vehicles with a gross vehicle weight of less than 3.5 tonnes from 1 December to 1 March (depending on weather conditions, however, already between October and April). Spikes are permitted from 1 October to 1 March.	Use permitted only on snow and ice-covered roads.	radial tyre 3 mm
Finland	Winter tyres are compulsory from 1 December to 28 February (in Lapland from mid-October to April), including on braked trailers. Spikes are permitted from 1 November to the first Monday after Easter.	Use permitted only on snow and ice-covered roads.	up to 3.5 t M+S 3 mm over 3.5 t Drive & steering axle M+S 5 mm otherwise 3 mm

Winter tyres in Europe*

	Tyres	Snow chains	Profile		Tyres	Snow chains	Profile
France	May be regulated by traffic signs. Spikes are permitted for vehicles with a maximum permissible weight of less than 3.5 tonnes from the Saturday before 11 November until the last Sunday in March. Maximum speed: 60/90 km/h.	May be indicated by traffic signs. Maximum speed 50 km/h.	M+S 3.5 mm	Italy	Winter tyres may be required between 15 November and 31 March, as indicated by road signs (in the Aosta Valley from 15 October to 15 April, in South Tyrol, the Bolzano urban area and on the A22 Brenner motorway from 15 November to 15 April). If the speed index is below the maximum speed of the vehicle, winter tyres may not be used from 15 May to 14 October. Spikes are permitted from 15 November to 15 March.	Carrying obligation, installation may be required by traffic signs. Maximum speed 50 km/h.	M+S 1.6 mm
Germany	Winter tyres (3PMSF) are mandatory in winter conditions for vehicles with a technically permissible gross weight of less than 3.5 tonnes on all axles and over 3.5 tonnes on the drive and front steering axles (M+S tyres manufactured before 1 January 2018 may be used until 30 September 2024).	Fitting may be required by traffic signs. Maximum speed 50 km/h.	up to 3.5 t 3PMSF 1.6 mm over 3.5 t Drive & steering axle 3PMSF otherwise M+S 1.6 mm	Latvia	Winter tyres are compulsory for vehicles with a maximum permissible weight of up to 3.5 tonnes and trailers from 1 December to 1 March. Spikes are permitted from 1 October to 30 April.	Use permitted only on snow and ice-covered roads.	up to 3.5 t M+S 4 mm, over 3.5 t 3 mm
Great Britain	May be regulated by traffic signs.	May be indicated by traffic signs.	M+S 1.6 mm	Liechtenstein	Winter tyres are recommended. From 1 November to 30 April, studded tyres are permitted on country roads for vehicles with a maximum permissible weight of up to 7.5 tonnes. Maximum speed 80 km/h.	Installation may be required by traffic signs.	no information
Greece	No information.	Use permitted only on snow and ice-covered roads.	drive axle 2 mm otherwise 1.6 mm	Lithuania	Winter tyres are compulsory for vehicles with a maximum permissible weight of up to 3.5 tonnes from 1 November to 1 April. Spikes are permitted from 1 November to 9 April.	Use permitted only on snow and ice-covered roads.	up to 3.5 t M+S 3 mm over 3.5 t 1.6 mm
Hungary	May be regulated by traffic signs.	Carrying obligation, installation may be required by traffic signs. Maximum speed 50 km/h.	M+S 1.6 mm	Luxembourg	Winter tyres are mandatory in winter road conditions. Spikes are permitted for vehicles with a maximum permissible weight of up to 3.5 tonnes from 1 December to 31 January. Maximum speed 70/90 km/h.	Use permitted only on snow and ice-covered roads.	M+S drive axle 1.6 mm
Iceland	Winter tyres compulsory from 15 November to 15 April. Spikes are permitted. Maximum 90 km/h.	Use permitted only on snow and ice-covered roads.	M+S 1.6 mm				
Ireland	Spikes are permitted. Maximum 96/112.	Use permitted only on snow and ice-covered roads.	1.6 mm				

Winter tyres in Europe*

	Tyres	Snow chains	Profile		Tyres	Snow chains	Profile
Macedonia	Winter tyres are compulsory from 15 November to 15 March. Alternatively, snow chains must be carried for at least one drive axle.	Summer tyres must be carried for at least one drive axle from 15 October to 15 March. Maximum speed 50 km/h.	up to 3.5 t 4 mm over 3.5 t 6 mm	Serbia	Winter tyres are compulsory in winter conditions from 1 November to 1 April.	Carrying requirement; installation may be mandated by traffic signs.	M+S 4 mm
Malta	No information.	no information	n. i.	Slovakia	Winter tyres are mandatory for vehicles with a maximum permissible weight of up to 3.5 tonnes when there is continuous snow cover, and for lorries with a maximum permissible weight of over 3.5 tonnes from 15 November to 31 March.	Carrying requirement; installation may be mandated by traffic signs.	M+S 3 mm
Montenegro	Winter tyres are compulsory in winter road conditions from 15 November to 31 March.	Carrying requirement for at least one drive axle. Installation may be required by traffic signs.	M+S drive axle 4 mm	Slovenia	Winter tyres are compulsory from 15 November to 15 April and in winter conditions. Alternatively, snow chains must be carried for at least one drive axle. For lorries with a maximum permissible gross weight of over 3.5 tonnes, winter tyres are only compulsory on the drive axle.	Summer tyres must be carried for at least one drive axle from 15 November to 15 April. Maximum speed 50 km/h.	drive axle 3 mm
Netherlands	no information	Use prohibited.	1.6 mm	Spain	Winter tyres (3PMSF) compulsory on all axles for high mountain roads. Exemptions for special vehicles.	Alternative to winter tyres for special vehicles between 3.5 t and 7.5 t, as well as buses. Maximum speed 50 km/h.	3PMSF 4mm
Norway	Winter tyres are mandatory for vehicles with a gross vehicle weight rating of over 3.5 tonnes on all axles, including trailers (M+S), drive and steering axles (3PMSF) from 15 November to 31 March. Spikes are permitted from 1 November (in Nordland, Troms and Finnmark from 16 October) until the first Sunday after Easter.	Mandatory requirement for vehicles with a gross vehicle weight rating of over 3.5 tonnes from 1 November (in Nordland, Troms and Finnmark already from 16 October) until the first Sunday after Easter.	up to 3.5 t M+S 3 mm over 3.5 t Drive & steering axle 3PMSF 5mm otherwise M+S	Sweden	Winter tyres are mandatory from 1 December to 31 March for vehicles with a maximum permissible weight of up to 3.5 tonnes on all axles (3PMSF) and over 3.5 tonnes on the drive axle (3PMSF) and all other axles (M+S). (Some M+S tyres will continue to be permitted until 30 November 2024, and for trailers even until 30 November 2028). Spikes are permitted from 1 October to 15 April (local exceptions in Stockholm, Uppsala and Gothenburg). Maximum speed 50 km/h.	Use only permitted on snow and ice-covered roads.	up to 3.5 t 3PMSF 5 mm over 3.5 t drive axle 3PMSF 5 mm otherwise M+S 5 mm trailer 1.6 mm
Poland	no information	Installation may be required by traffic signs.	M+S 1.6 mm Buses 3mm				
Portugal	no information	Installation may be required by traffic signs.	M+S 1.6 mm				
Romania	Winter tyres are mandatory in winter road conditions. For lorries with a maximum permissible gross weight of over 3.5 tonnes, winter tyres are only mandatory on the drive axle.	Mandatory requirement for vehicles with a maximum permissible gross weight of over 3.5 tonnes; installation may be required by traffic signs.	M+S drive axle 1.6 mm				
Russia	Winter tyres are compulsory from December to February.	Snow chains are recommended.	M+S 4 mm				

Winter tyres in Europe*

	Tyres	Snow chains	Profile
Switzerland	Winter tyres are recommended. From 1 November to 30 April, studded tyres are permitted for vehicles under 7.5 tonnes. Maximum speed 80 km/h.	Mandatory to carry for at least one drive axle; installation may be required by traffic signs.	1.6 mm
Turkey	Winter tyres may be mandatory in winter conditions from 1 December to 1 April. For vehicles with a gross vehicle weight rating of over 3.5 tonnes, winter tyres are only mandatory on the drive axle.	Use only permitted on snow-covered roads.	up to 3.5 t M+S 1.6 mm over 3.5 t M+S drive axle 4 mm
Ukraine	Winter tyres are compulsory from November to April. Studded tyres are permitted.	Use only permitted on snow-covered roads.	M+S 6 mm

*ALL INFORMATION PROVIDED WITHOUT GUARANTEE

**STABILITY MEETS
EFFICIENCY:
KRONE TRUSTED
PRIME:TYRE.**



NEW

The KRONE TRUSTED PRIME:TYRE is ideal for transporting large volumes of fuel - it rolls easily, saves money and combines economy with impressive performance.



www.krone-trailerparts.com/trusted



Care and maintenance

Every tyre change involves risks and should therefore only be carried out by trained and appropriately equipped personnel.

Disassembly

- Before dismantling the tyre, always check that all components of the rim/tyre are correctly seated.
- Remove the valve insert and let the air out of the tyre completely before removing the complete wheel from the vehicle.
- Before carrying out any repair work, remove the valve insert and insert holder to ensure that all air is completely released.
- ⚠ Never lean, stand or reach over the tyre or rim while the air is escaping.
- ⚠ Never attempt to press down tyre beads when the tyres are inflated.
- ⚠ Do not strike the tyre or rim with any heavy object.

Assembly

- Always check the inside of the tyre for any loose cord layers, cuts, punctures or other damage to the casing.
- Before inserting the tube, always check the inside of the tyre for dirt, liquids or other foreign matter and remove them.
- Never use a damaged, warped or kinked hose.
- Always use new inner tubes and new rim tapes for new tyres.
- Before inserting the hose, check that it is clean.
- Only use lubricants that are suitable for tyre fitting. Do not use any antifreeze agents, silicones or petroleum-based lubricants.
- Do not strike the tyre or rim with any heavy object.

- Always ensure that all rim parts are correctly positioned before inflating the tyre.
- Always place the complete wheel (tyre + rim) in a safety cage while inflating, setting and/or filling the tyre for operation.
- Keep your distance during filling and always use an extension hose with a pressure gauge.
- Never attempt to fit rings to tyres that are partially or fully inflated.
- Never refill a flat tyre or a tyre with insufficient air pressure without first checking it thoroughly (inner tube, tyre, rim) for any damage.
- Check the valve inserts and replace any damaged or leaking inserts.
- Adjust the tyre pressure of the tyres when cold to the recommended values.
- Always fit radial tyres in conjunction with radial inner tubes and radial rim tapes.

Minimum tread depth

The wear limit at which a tyre change is mandatory and is 1.6 mm for lorry tyres in Germany.

The tread indicators are located in the main tread grooves at the height of the markings (TWI or Δ) on the tyre shoulder.

Care and maintenance

Tyre pressure

Incorrect tyre pressure has a negative impact on fundamental safety-related performance characteristics such as the strength of the carcass, the stability and handling of the vehicle, the grip and traction of the tyres, and the sensitivity to impact with obstacles.



- Heavy wear on the sides
- Poor stability and grip
- Low mileage
- Higher fuel consumption

Risk of damage and flat tyres!

- + Good stability and grip
- + High mileage
- + Optimal fuel consumption

- Heavy wear in the centre
- Poor stability and grip
- Low mileage
- Higher fuel consumption

Risk of damage and flat tyres!

It is essential to check the tyre for remaining tread depth, wear pattern and damage, and in particular the tyre pressure. It is advisable to follow certain recommendations when doing so.

- Check the tyre pressure regularly and adjust it if necessary when the tyres are cold.
- Check the tyre pressure again 24 hours after refitting the tyres.
- Use a calibrated and accurate pressure gauge.
- Never deflate tyres when they are warm.
- Never inflate a lorry tyre to more than 10 bar.

Rotate tyres

Tyre rotation, also known as tyre changing, reduces tyre costs, prevents uneven wear and extends service life.

- 1. Rotate the tyre on the rim while it remains in the same wheel position**
 - Counteracts one-sided shoulder wear.
 - Also promotes the use of tyres that are susceptible to high abrasion or sidewall wear.
- 2. Swap the tyre on the same axle from right to left**
 - Compensates for the effect on different wear rates that occur on vehicles mainly used in regional transport.
- 3. Switch the tyres from the outside to the inside**
 - Balances wear on twin tyres and brings the outer sidewall to the inside.
- 4. Switch the tyres from one axle to the other**
 - On 6x2 vehicles, the tyres between the 1st and 3rd axles compensate for different cornering loads and thus wear more evenly. This means that the front axle lasts longer.
- 5. Reposition the trailer tyres: 1st axle on the 3rd axle, 3rd axle on the 2nd axle and 2nd axle on the 1st axle**
 - Maximises service life and resistance to irregular wear on all trailer axles.

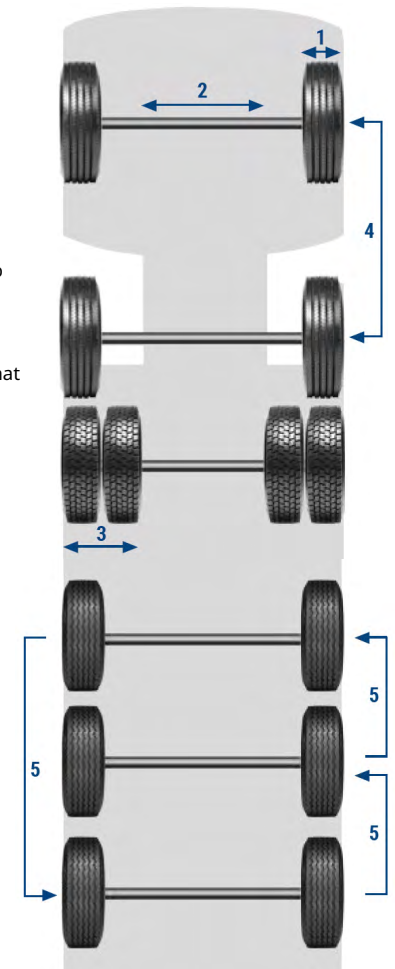

Storage

Tyres should generally be stored in a cool, dry place away from direct sunlight. Storage near fuels, lubricants, solvents and chemicals must be avoided at all costs.

Tyres should preferably be stored upright. If this is not possible, the stack height should not exceed approx. 1.5 m in order to avoid significant deformation of the bottom tyre. This applies equally to unmounted tyres and tyres mounted on complete wheels.

Marking and energy label

Tyre labelling provides information about rolling resistance, wet braking performance and external rolling noise. This information helps you make a cost- and environmentally-conscious choice.

Regulation (EC) 1222/2009 applies to car, truck and bus tyres manufactured before 1 May 2021. From the specified date of manufacture onwards, the new Regulation (EU) 2020/740 applies. In addition to changes in the presentation of label values for external rolling noise, this includes a labelling option for snow and ice grip. All of the following information refers specifically to the new regulation.

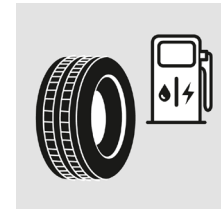
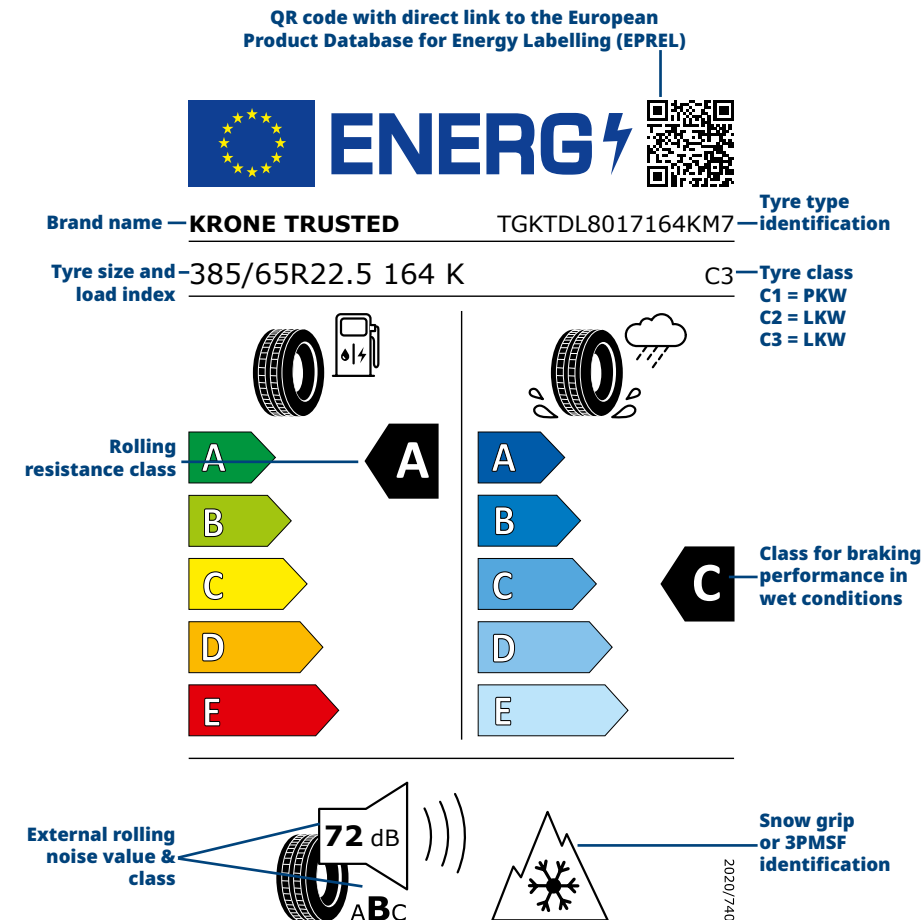

Rolling resistance

In addition to driving conditions and driver behaviour, the rolling resistance of the tyres **can affect** the fuel consumption of the vehicle. The measured rolling resistance (rolling resistance coefficient) of the tyre is classified into classes A to E.

A car equipped entirely with class A tyres would have 7.5% lower fuel consumption compared to a car equipped with class E tyres. For commercial vehicles, this value can be even higher.

Rolling resistance is measured in N/kN at 80 km/h and a load of 80% of the maximum tyre load capacity on a drum test bench.



Braking performance in wet conditions

When braking hard on wet roads, the tyre's grip has a direct impact on passenger safety, alongside other vehicle-specific factors. Wet grip also ranges from class A (shortest braking distance) to class E (longest braking distance).

If a car brakes from 80 km/h to a standstill on a wet road, the braking distance with class E tyres is up to 18 m longer than with class A tyres. The difference is even more significant for commercial vehicles.

The adhesion value between the road surface and the tyre is measured on a watered track in comparison to a standardised reference tyre (SRTT – Standard Reference Test Tyre). The standardised measured value (reference temperature and reference grip of the measuring track) is assigned to the corresponding class.

Marking and energy label

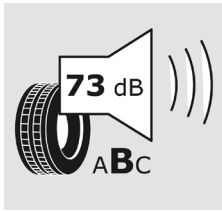

External rolling noise

In addition to engine noise, tyres can also cause noise. That is why the EU has set limits for the noise emitted by tyres to the outside world. These limits vary and depend, for example, on the width and type of tyre.

The external rolling noise value is given in decibels and in classes A to C:

Class A is more than 3 dB below the EU limit value. Class B is up to 3 dB below the EU limit value. Class C exceeds the EU limit value. It is not permitted in road traffic.

The noise level of the tyre is measured in dB(A) on a measuring track specified in accordance with ISO 10844 when the vehicle is rolling at 80 km/h.

After standardisation to the reference temperature, the tyre is assigned to the specified classes.



Ice grip

For car winter tyres (class C1) that are specially designed for use on icy roads in Northern Europe, a certain minimum level of grip on ice is confirmed. This is achieved, among other things, by using special rubber compounds (soft compounds). Such tyres are generally not intended for use outside Northern Europe.

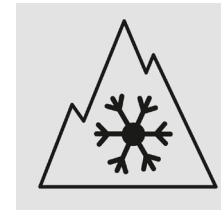

Snow grip

In order for a tyre to carry the snowflake or alpine symbol (3 Peak Mountain Snow Flake, or 3PMSF symbol for short), it must demonstrate a certain level of braking and traction performance on compacted snow compared to a standardised reference tyre (SRTT – Standard Reference Test Tyre).

Hier Antrag stellen



Eligibility

The EU subsidises the purchase of tyres with 3PMSF marking. Tyres on trailer axles are generally subsidised at 80% of the net value of the goods. For tyres on steering and drive axles, however, the amount of the subsidy also depends on the rolling noise. Applications for subsidies can be submitted to the Federal Office for Logistics and Mobility: www.antrag.gbbmdv.bund.de



Vecto

In Europe, significantly reducing emissions is the top priority in the transport sector. To enable companies and manufacturers to simulate the emissions of different vehicle configurations in advance, the EU has introduced a tool: the Vehicle Energy Consumption Calculation Tool, or VECTO for short.

We would be happy to assist you with this topic. Please contact us at tyre-support@krone.de.

Marking and energy label

The QR code on the energy label and the manufacturer's website link to the European product database. This public area contains the most important data on all tyres manufactured since 1 August 2017.

Tyres

REGULATION (EU) 2020/740 on the labelling of tyres with respect to fuel efficiency and other parameters

Krone Trusted KT231 KT-100001

General Information ^

Tyre class	C3
Tyre size designation	385/65 R 22.5
Load-capacity index (single/dual)	164/-
Speed category symbol	J (100 km/h)

Additional Service Description

Load-capacity index (single/dual)	
Speed category symbol	

Fuel efficiency
 Wet grip
 External rolling noise
 Tyre for use in severe snow conditions

Krone Trusted KT-100001

385/65 R 22.5 164 J C3

C

B

2020/740

European Product Database for Energy Labelling (EPREL)

Regulation (EU) 2017/1369 introduced the EPREL product database in Europe. EPREL stands for European Product Registry for Energy Labelling. All products with an energy label must be entered in this database. This applies to all energy-related products. Registration is required before sale in Europe. EPREL has been accessible via the European internet portal since 1 January 2019.

The EU Commission develops and maintains the database. The database consists of a public section and a confidential section for conformity. The public section has been available since the second quarter of 2020. Consumers can access information there. Retailers and experts also have access. Product data sheets and energy labels, for example, are available for download.

- 1 Download energy label
- 2 Download product data sheet in local language

Product data sheet





Delegated Regulation (EU) 2020/740

Name or trade mark of the supplier	Krone Trusted
Trade name or trade mark	KT231
Tyre type identifier	KT-100001
Tyre size designation	385/65 R 22.5
Load-capacity index (for single mounting)	164
Load-capacity index (for dual mounting)	
Speed category symbol	J (100 km/h)
Fuel efficiency class	C
Wet grip class	B
External rolling noise class	B
External rolling noise value	72 dB
Tyre suitable for extreme snow conditions	yes
Date of commencement of production	23/23
Date of end of production	-
Additional information	
Load-capacity index for Additional Service Description (for single mounting)	164
Load-capacity index for Additional Service Description (for dual mounting)	
Speed category symbol (for the additional service index)	J





TYRE:COMFORT

KT231

-  3PMSF identification
-  M+S Identification
-  Long-distance transport
-  Local transport
-  5,000 kg load capacity

- **Competition:** Sailun, Westlake, Barum, Matador, Sava, Truckstar, Lauffen, Kumho, Taurus, Nokian, Apollo, BF Goodrich, Falken
- **Low budget market competitors:** Fullrun, Linglong, Austone, Double Coin, Barkley, Petlas, Goodride, Bison, Leao, Anteo, Trazano
- **Product advantages:** High mileage, robustness, high load capacity, wide profile, retreadability
- **Cost-effectiveness:** 20% cost reduction compared to Premium (lower price per kilometre)
- **Class:** High Budget





PRODUCT-RANGE	Pro-file	Load/Speed	Profile depth	Weight				M+S	3PMSF	Ice grip
385/65R22,5	KT231	164J	18 mm	78	C	B	72 dB	✓	✓	-

Click here to go to the tyre shop:







COMFORT:TYRE

Trailer

-  3PMSF identification
-  M+S Identification
-  Long-distance transport
-  Local transport
-  5,000 kg load capacity

- **Competition:** Sailun, Westlake, Barum, Matador, Sava, Truckstar, Lauffen, Kumho, Taurus, Nokian, Apollo, BF Goodrich, Falken
- **Low budget market competitors:** Fullrun, Linglong, Austone, Double Coin, Barkley, Petlas, Goodride, Bison, Leao, Anteo, Trazano
- **Product advantages:** High mileage, robustness, high load capacity, wide profile, retreadability
- **Cost-effectiveness:** 20% cost reduction compared to Premium (lower price per kilometre)
- **Class:** High Budget

PRODUCT-RANGE	Pro-file	Load/Speed	Profile depth	Weight				M+S	3PMSF	Ice grip
385/65R22,5	-	164K	15 mm	72,7	C	C	72 dB	✓	✓	-



Click here to go to the tyre shop:







ECO:TYRE

Trailer

-  3PMSF identification
- M+S** Identification
-  Long-distance transport
-  5,000 kg load capacity



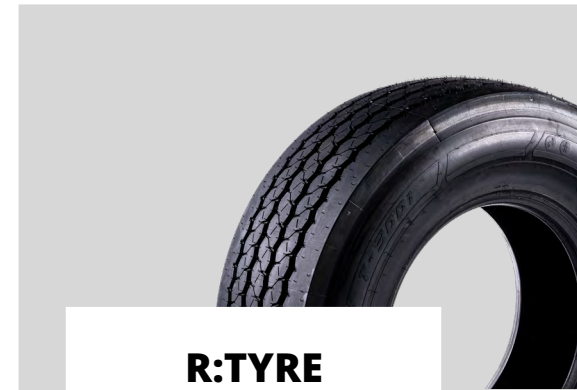

- **Competition:** Sailun, Westlake, Barum, Matador, Sava, Truckstar, Lauffen, Kumho, Taurus, Nokian, Apollo, BF Goodrich, Falken
- **Low budget market competitors:** Fullrun, Linglong, Austone, Double Coin, Barkley, Petlas, Goodride, Bison, Leao, Anteo, Trazano
- **Product advantages:** Low rolling resistance, CO2 savings, carcass certification, retreadability, high tread depth for Label A
- **Cost-effectiveness:** 2-3% fuel savings compared to C label
- **Class:** High Budget

PRODUCT-RANGE	Pro-file	Load/Speed	Profile depth	Weight				M+S	3PMSF	Ice grip
385/65R22,5	-	164K	15 mm	70,8	A	C	72 dB	✓	✓	-





R:TYRE

T3001

-  3PMSF identification
- M+S** Identification
-  Long-distance transport
-  Local transport
-  5,000 kg load capacity

- **Competition:** Remix, Contire, Bandag, Ringread
- **Low budget market competitors:** Regional cold renewal without ring tread
- **Product advantages:** CO2 savings, sustainability, high mileage, retreaded, 5-year warranty, new tyre appearance
- **Cost-effectiveness:** new tyre level
- **Class:** High retread



PRODUCT-RANGE	Pro-file	Load/Speed	Profile depth	Weight				M+S	3PMSF	Ice grip
385/65R22,5	-	164K	15 mm	70,8	-	-	-	✓	✓	-







PRIME:TYRE

Trailer

-  3PMSF identification
- M+S** Identification
-  Long-distance transport
-  4,500 kg load capacity





- **Competition:** Sailun, Westlake, Barum, Matador, Sava, Truckstar, Lauffen, Kumho, Taurus, Nokian, Apollo, BF Goodrich, Falken
- **Low budget market competitors:** Fullrun, Linglong, Austone, Double Coin, Barkley, Petlas, Goodride, Bison, Leao, Anteo, Trazano
- **Product advantages:** Low rolling resistance, wide profile, economy, optimum fuel efficiency
- **Cost-effectiveness:** 1-2% fuel savings compared to C label
- **Class:** High Budget

PRODUCT-RANGE	Pro-file	Load/Speed	Profile depth	Weight				M+S	3PMSF	Ice grip
385/55R22,5	-	160K	16 mm	63,6	B	C	72 dB	✓	✓	-





COMFORT:TYRE

Trailer

-  3PMSF identification
- M+S** Identification
-  Long-distance transport
-  Local transport
-  4,500 kg load capacity

- **Competition:** Sailun, Westlake, Barum, Matador, Sava, Truckstar, Lauffen, Kumho, Taurus, Nokian, Apollo, BF Goodrich, Falken
- **Low budget market competitors:** Fullrun, Linglong, Austone, Double Coin, Barkley, Petlas, Goodride, Bison, Leao, Anteo, Trazano
- **Product advantages:** High mileage, robustness, wide tread
- **Cost-effectiveness:** 20% Cost reduction compared to Premium (lower price per kilometre)
- **Class:** High Budget



PRODUCT-RANGE	Pro-file	Load/Speed	Profile depth	Weight				M+S	3PMSF	Ice grip
385/55R22,5	-	160K	16 mm	63,9	C	C	72 dB	✓	✓	-







ECO:TYRE

KT2

-  3PMSF identification
- M+S** Identification
-  Long-distance transport
-  5,000 kg load capacity





- **Competition:** Sailun, Westlake, Barum, Matador, Sava, Truckstar, Lauffen, Kumho, Taurus, Nokian, Apollo, BF Goodrich, Falken
- **Low budget market competitors:** Fullrun, Linglong, Austone, Double Coin, Barkley, Petlas, Goodride, Bison, Leao, Anteo, Trazano
- **Product advantages:** Low rolling resistance, CO2 savings, high load capacity, wide profile
- **Cost-effectiveness:** 2-3% fuel savings compared to C label
- **Class:** High Budget

PRODUCT-RANGE	Pro-file	Load/Speed	Profile depth	Weight				M+S	3PMSF	Ice grip
435/50R19,5	KT2	164J	14 mm	67	A	B	74 dB	✓	✓	-





PRIME:TYRE

KT2

-  3PMSF identification
- M+S** Identification
-  Long-distance transport
-  Local transport
-  5,000 kg load capacity

- **Competition:** Sailun, Westlake, Barum, Matador, Sava, Truckstar, Lauffen, Kumho, Taurus, Nokian, Apollo, BF Goodrich, Falken
- **Low budget market competitors:** Fullrun, Linglong, Austone, Double Coin, Barkley, Petlas, Goodride, Bison, Leao, Anteo, Trazano
- **Product advantages:** Cost-effectiveness, low rolling resistance, optimum fuel efficiency, high load capacity, wide profile
- **Cost-effectiveness:** 20% cost reduction compared to Premium (lower price per kilometre)
- **Class:** High Budget

PRODUCT-RANGE	Pro-file	Load/Speed	Profile depth	Weight				M+S	3PMSF	Ice grip
435/50R19,5	KT2	164J	14 mm	67	B	B	74 dB	✓	✓	-







PRIME:TYRE

KT2

-  3PMSF identification
- M+S** Identification
-  Long-distance transport
-  Local transport
-  5,000 kg load capacity

- **Competition:** Sailun, Westlake, Barum, Matador, Sava, Truckstar, Lauffen, Kumho, Taurus, Nokian, Apollo, BF Goodrich, Falken
- **Low budget market competitors:** Fullrun, Linglong, Austone, Double Coin, Barkley, Petlas, Goodride, Bison, Leao, Anteo, Trazano
- **Product advantages:** Cost-effectiveness, low rolling resistance, optimum fuel efficiency, high load capacity, wide profile
- **Cost-effectiveness:** 20% cost reduction compared to Premium (lower price per kilometre)
- **Class:** High Budget

PRODUCT-RANGE	Pro-file	Load/Speed	Profile depth	Weight				M+S	3PMSF	Ice grip
445/45R19,5	KT2	164J	14 mm	68	B	B	74 dB	✓	✓	-

Click here to go to the tyre shop:

